

Model BCV1 Bottomless Conveyor

Operation Manual

Rev A

CONTENTS

1. ILLUSTRATIONS	2
2. SAFETY REMINDER	4
3. INTRODUCTION.....	5
4. SPECIFICATIONS	7
General	
Inputs	
Dimension	
5. GENERAL INFORMATION	8
What It Does	
Features and Capabilities	
Options	
6. INSTALLATION.....	9
Unpacking	
Install BCV1 onto Lift Stand	
Apply Service	
Basic Operational Test	
Integrate with Line	
7. SPEED CONTROL.....	11
8. SET UP	12
Set Up Check List	
Adjust Machine Height	
Adjust Belt Spacing	
9. MAINTENANCE.....	13
Cleaning Recommendations	
Washdown	
Cleaning Solutions	
Stainless Steel	
Anodized Aluminum	
Electricals/Electronics	
Preventative Maintenance	
10. TECHNICAL INFORMATION	14
Principal of Operation	
Cycle of Operation	
Troubleshooting	
Index of Technical Notes and Drawings	

(Technical Notes/Drawings Begin After Last Page)

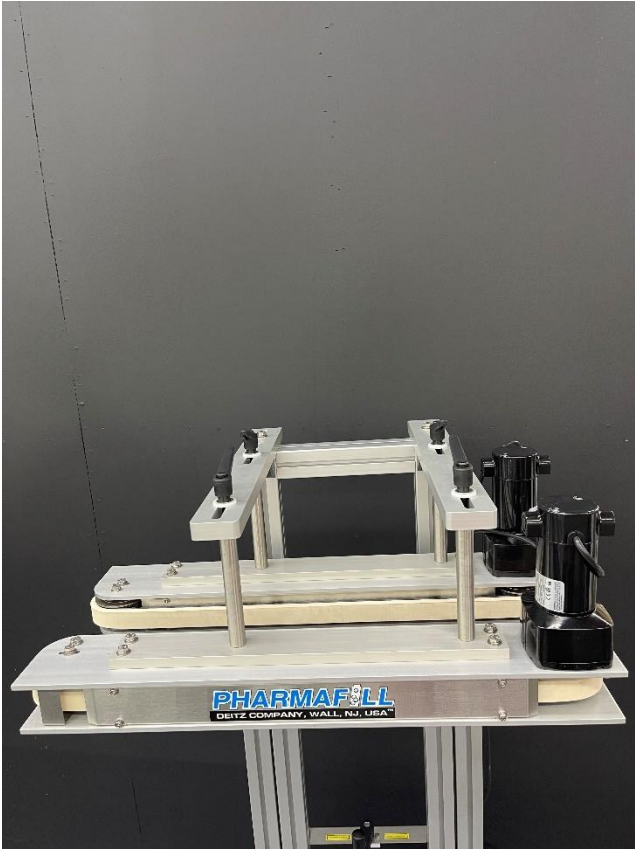

FRONT VIEW

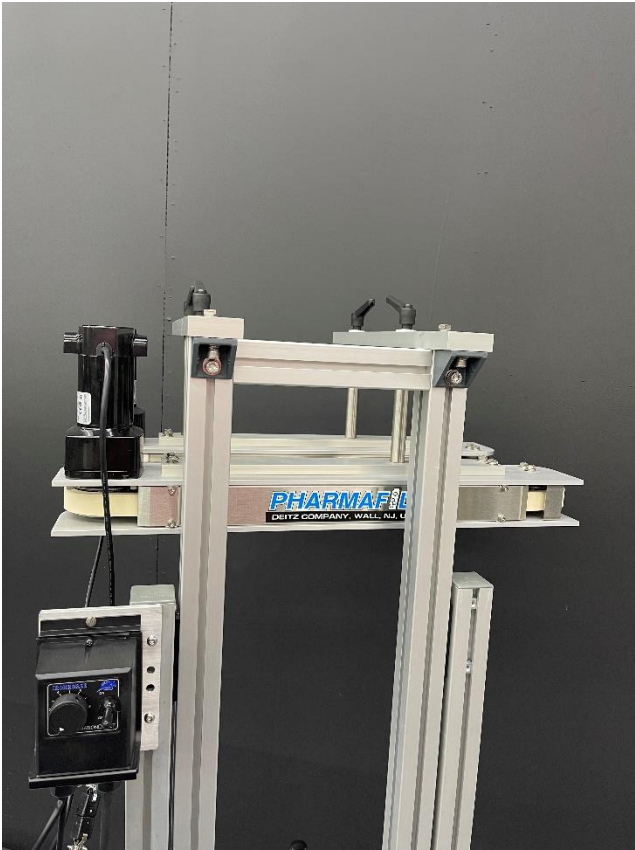

REAR VIEW



VIEW FROM
UPSTREAM



VIEW FROM
DOWNSTREAM

Section 2 - SAFETY REMINDER



Warning



This machine contains moving parts and operates automatically. This may present a hazard to personnel.

Never operate this machine with any covers or guards removed or any guard switches or safety devices removed or bypassed.

Only people who have been correctly trained should operate or clean this machine.

Only people who are correctly qualified and trained should carry out maintenance, installation, or any other service work.



Never clean or service the machine without isolating the electrical supply and isolating the air supply.



Always test for the presence of voltage before touching or working on electrical components.

Note that there might be other requirements that could apply.

Refer to the manuals supplied by the component manufacturers for further safety instructions.

Section 3 - INTRODUCTION

Thank you for purchasing a Pharmafill Model BCV1 Bottomless Conveyor. We at Deitz Company hope you will find that the Model BCV1 meets or exceeds your expectations and requirements for an affordable, reliable, and innovative addition to your packaging operation.

Pharmafill products are designed and manufactured by Deitz Company Inc., in Wall, NJ, USA. We have manufactured machinery for the bottle filling industry since 1966 and started our Pharmafill line in 1993. We are a small (but growing) family-owned business that emphasizes quality, innovation, and superior customer service.

If you have any questions or comments, please contact us by phone or visit our website. Chances are someone whose last name is Deitz will handle your inquiry personally.

Deitz Company Inc.
PO Box 1108
1750 Route 34
Wall, NJ, USA 07719

Tel 732-681-0200
Fax 732-681-8468

E-mail
support@pharmafill.com

Web site deitzco.com or
pharmafill.com

The operation manual is designed to make it easier for you to know the machine and to make use of its intended range of operation. It contains important instructions on how to operate the machine safely, adequately, and economically. Observing these instructions helps to avoid risks, to reduce cost for repair work and machine downtime, and enhances the machine's operational reliability and lifetime.

The operation instructions are to be supplemented by further instructions due to existing national regulations on accident prevention and environmental protection.

Section 3 – INTRODUCTION (cont'd)

If used in compliance with the instructions contained in this manual and if safety devices are regularly maintained and properly working, this machine is not dangerous to the operator.

This manual is to be kept accessible to all operators using this machine and it is assumed that, before use, the operator will read fully and understand this manual and will follow instructions stated within.

As this machine may be used in the packaging of hazardous substances the operator should be aware of the precautions required for these substances.

In addition to the operating instructions and the binding regulations on accident prevention valid in the country where the machine is being used and at its operational site, the recognized technical rules on safe and proper working must be observed as well.

These operating instructions and the information contained therein have been compiled with due care and attention. However, DEITZ COMPANY does not take any responsibility for misprints, translation errors or other errors and any damages resulting there from.

DEITZ COMPANY retains the right to make changes in the described products to improve functionality, reliability, and other design considerations. The measurements or data shown on schematics, sketches and photos are not binding. They are for description purposes.

The information and drawings found in the operation manual are the intellectual property of DEITZ COMPANY and may not be copied or given to third parties.

LEGAL NOTICE: DEITZ COMPANY™, PHARMAFILL™ and any graphic representations of the same are legal trademarks of Deitz Company Inc. and may not be used by others without specific written permission from Deitz Company.

Section 4 - SPECIFICATIONS (Also see technical info at end of manual)

GENERAL

Model	BCV1 Bottomless Conveyor
Type	AD1198 REV A
Product Capability	9 lbs (4kg)
Maximum Rate	100 feet/minute

INPUTS

Voltage	110 VAC ¹ (Optional 220VAC)
Cycles	50/60 HZ
Phase	1
Amperage	1.0A
Compressed Air	N/A
Room Humidity	85% RH non-condensing

DIMENSIONS

Floor Footprint	16" wide x 27-1/2" deep (41cm X 70cm)
Height ²	Short Variable 35" to 46" (89cm to 117cm) Standard Variable 47" to 58" (120cm to 147cm)
Container Size	0" – 6" (0cm – 15cm)
Weight	Fully assembled: 94 lbs (42 Kg) Front Belt Assembly: 29 lbs (13 Kg) Rear Belt Assembly: 29 lbs (13 Kg) Lift Stand with Mounting Bars: 36 lbs (16 Kg)

OTHER

Ideal Conveyor Height	36" +/- 1" (92cm +/- 2.5cm)
Construction Materials	Stainless Steel, (Anodized) Aluminum,

Notes:

1. Other input voltages are available as factory options if specified at the time of order
2. May be adjusted further by adjusting or modifying leveling feet.

Section 5 – GENERAL INFORMATION – Getting to know the machine

1. WHAT IT DOES

The motorized Bottomless Conveyor serves as an active transfer mechanism. It moves containers from one point to another without relying on dead plates or other passive diverters that use back pressure from the containers. The dual belt design promotes smoother transfers with no tipping over and no spillage.

This device can be set above a laser marking device, thermal inkjet printer, continuous inkjet printer or other coding system within your existing packaging line without disrupting the flow.

2. FEATURES AND CAPABILITIES – (for specifications, please see Section 4)

Variable speed control to match line speed

Quickly adjusts to suit container height and width

Transfers bottles without passive diverters

3. OPTIONAL FEATURES

Standard Conveyor Mount

Lift Stand (LS-BCV1) Mount

BCV1 Mounting Bars

Adjustable Ratchet Handles

Casters

6" Leveling Pads

Customized Printer Mounting Kits

Please contact Deitz Company for more details

Section 6 – INSTALLATION AND COMMISSIONING

NOTE: PLEASE RETAIN THE PACKING CRATE AND MATERIALS UNTIL THE MACHINE IS FULLY OPERATIONAL, TESTED AND APPROVED.

1. Unpacking

- a. Carefully remove the cardboard cover from the box.
- b. Remove all packing materials and any additional boxes that may be inside.
- c. Cut the plastic straps that hold the lift stand to the box.
- d. Remove the LS-BCV1 Lift Stand from the box and place it on the floor.
- e. Remove the remaining box containing two (2) BCV1 assemblies, front and rear.
- f. Place each BCV1 Bottomless Conveyor unit on a working surface (a table or sturdy cart).
- g. Remove any shrink-wrap, bags, bubble wrap and/or protective cardboard inserts from the lift stand and conveyor units.
- h. Inspect all supplied equipment for damage.
- i. If any damage is present, please notify DEITZ COMPANY immediately. If possible, send a photo.
- j. Follow the procedures on the following pages to assemble and test the machine.

2. Install BCV1 onto Lift Stand

- a. On a table or sturdy flat surface, position each device so belts are facing each other. This is how they will be oriented for installation.
- b. Place a ratchet handle with washers in each of the slots on the BCV1 Mounting Bars.
- c. Have a helper hold one unit in place under the Mounting Bars and install it by screwing ratchet handles into BCV1 Mounting Posts.
- d. Follow the same procedure for the second unit.

Refer to pages 2-3 in this manual for images of standard setup

3. Apply Service - Connectors for motors and speed control are color-coordinated

- a. Connect two ends with red tape.
- b. Connect two remaining connectors.
- c. Make sure Speed Control Power Switch is in OFF position.
- d. Connect power plug to 110 VAC

4. Basic Operational Test

a. Move Power Switch to ON position

b. Turn Speed Dial to ONE (1)

Motors should engage and belt should be moving very slowly

c. Turn Speed Dial to TEN (10)

Machine should be running at full speed

d. Turn Speed Dial to FIVE (5)

5. Integrate with Line

a. Roll BCV1 into position on your packaging line

b. Adjust the height of your machine so the belts will grab your sample

c. Adjust the space between the belts so the sample will fit between them

Section 7 – Speed Control



Shown here:
Speed control
is mounted on
the LEFT

Variable Speed Control can be used to match the speed of other transfer devices and can easily accelerate or decelerate. Mounting hardware is located on either side of the lift stand based on the direction of flow and motor position.

For best results:

- Use the ON/OFF switch to control power
- Use the 0-10 dial to control speed

Section 8 – Set Up

1. Set Up Checklist

- Motors are connected to Speed Control
- Speed Control is connected to 110 VAC
- Belt Assemblies are secured to BCV1 Mounting Bars
- Belt Assemblies are facing each other
- Lift Stand is secure in place on leveling pads

2. Adjust Machine Height

- Use the crank handle on the lift stand to raise or lower the machine

3. Adjust machine Width

- Use the ratchet handles on the BCV1 Mounting Bars to adjust Belt Spacing

Section 9 - CLEANING RECOMMENDATIONS

Washdown

This machine is not waterproof and is not intended for full wash down. If full washdown is performed on the equipment near the machine, it must be completely protected by a waterproof cover or by other means. Washdown will void the warranty.

Cleaning solutions

Stainless steel is resistant to most cleaning solutions. Other contact materials such as aluminum and nonmetallics (plastics, or rubber) are generally less corrosion-resistant and care should be exercised in their cleaning. Aluminum is readily attacked by acids as well as highly alkaline cleaners, which can render the surface non-cleanable. Rubber belts are subject to stress cracking and clouding from prolonged exposure to corrosive cleaning agents. Use a USDA approved sanitizing solution that is safe for all materials listed below, in a spray bottle, by lightly wiping down all contact surfaces. In the absence of such a cleaner, recommendations follow.

Recommendations

Stainless steel: This material is resistant to damage from most cleaners. Routine cleaning can be done with soap and water, alcohol, or acetone.

Anodized aluminum: Any highly acidic or alkaline cleaner will etch the aluminum over time and damage it. Soap and water, or alcohol is acceptable.

Conveyor Belts: Cleaning rubber with alcohol or acetone will damage them and should never be used. They may be safely cleaned with soap and water.

Preventative Maintenance

Idler Pulleys and Motor Pulleys should routinely be inspected for smooth operation.

(Assembly diagrams can be found in Technical Documents - Section 10.4)

Section 10 – TECHNICAL INFORMATION

Principal of Operation

The BCV1 Bottomless Conveyor is designed to transfer containers from one moving device to another, such as a standard sanitary conveyor or turntable. Certain options allow for side- or bottom-print application

Cycle of Operation

The BCV1 Bottomless Conveyor has only one run function. When properly connected, belts will move in the same direction and at the same speed. Speed can be adjusted with Variable Speed Control.

Troubleshooting

- Turn Speed Control ON but the belts do not move
Check that power is properly supplied from 110 VAC to Speed Control and each motor.
Check that Speed Dial is above ZERO
- Belts move in the wrong direction
Switch the connections from the Speed Control to the motors.
- Power is properly supplied but belts do not move
Contact Customer Support at Deitz Company

Index of Technical Notes and Drawings (document section begins after this page)

<u>Doc. No.</u>	<u>Title</u>	<u>No. of Pages</u>
DATASHEET_BCV1	Dimensions and specification	1
Addendums or additional technical data		
_____	_____	---
_____	_____	---
_____	_____	---
_____	_____	---
_____	_____	---
_____	_____	---
_____	_____	---
_____	_____	---
_____	_____	---

PHARMAFILL MODEL BCV1 BOTTOMLESS CONVEYOR

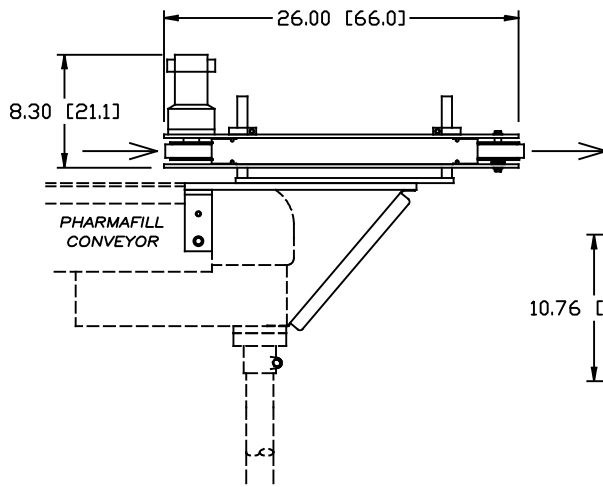

CONVEYOR MOUNTING
LEFT SIDE VIEW

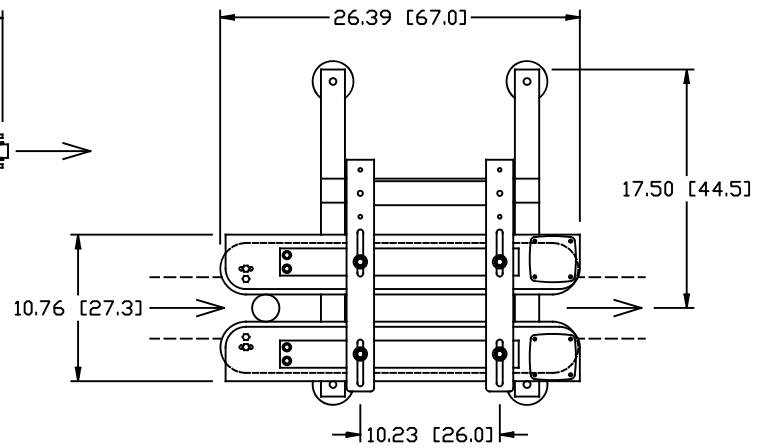

LIFT STAND MOUNTING
OVERHEAD

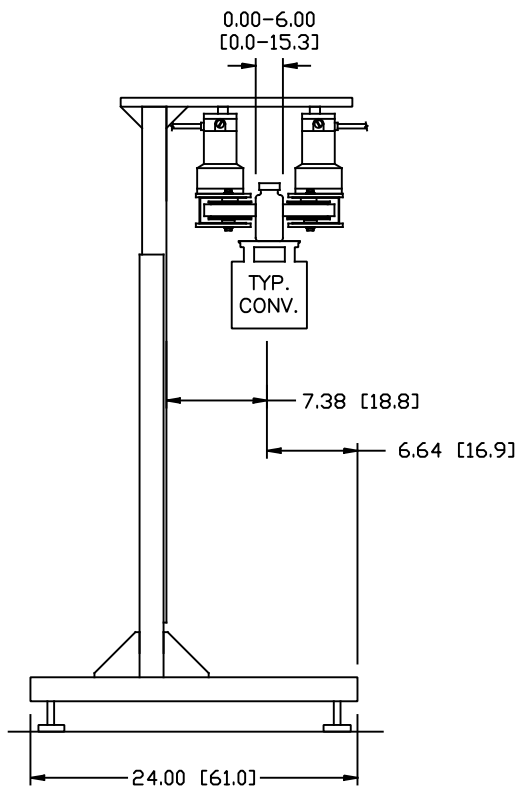

LIFT STAND MOUNTING
LEFT SIDE

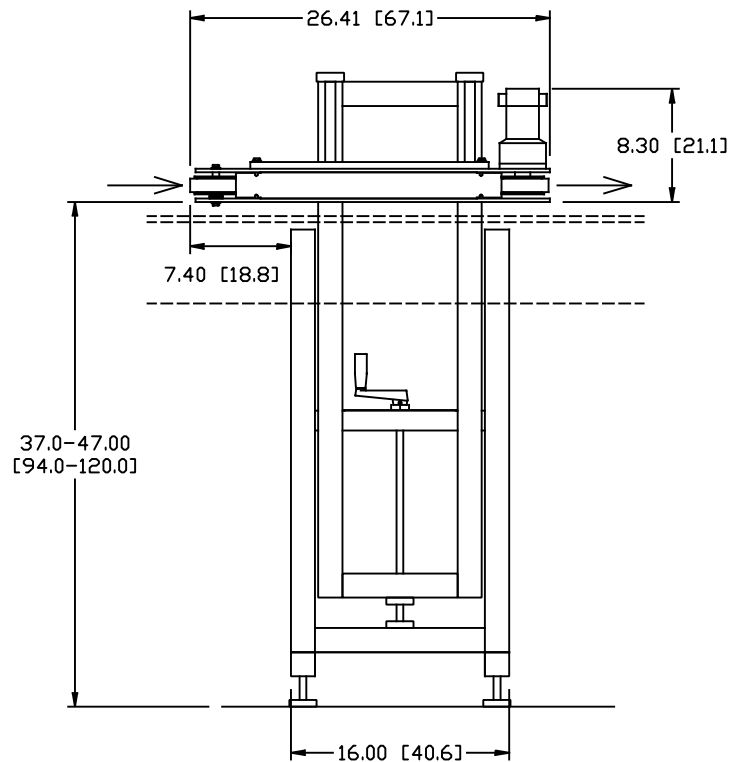

LIFT STAND MOUNTING
FRONT

ELECTRICAL REQUIREMENTS: 110 VAC 1.0 AMPS
DIMENSIONS ARE IN INCH & [CM].

SPECIFICATIONS AS OF MARCH 2015. MAY CHANGE AT ANY TIME.