

***Model TC4 Electronic Counter***  
**Operation Manual**

## CONTENTS

1. General Illustrations.....	pgs II thru XI
2. Safety Reminder.....	1
3. Introduction.....	2
4. Specifications.....	4
5. Installation and Commissioning.....	5
5.1. Unpacking.....	5
5.2. Installing Head Centering Wheel.....	6
5.3. Electric.....	7
5.4. Connect Low Pressure Air Supply (AS1 Air Supply).....	8
5.5. Systems Check.....	9
6. General Information.....	10
6.1. Standard Features and Capabilities.....	10
6.2. Additional Features.....	10
7. Operation.....	11
7.1. Control Panel.....	11
7.1.1 HMI Data Section.....	12
7.1.2 HMI Action Keys.....	12
7.1.3 Bottle Indicator Sensors.....	13
7.2. Speed Controls.....	13
7.3. Counting Sensor.....	14
7.3.1. Threshold Adjustment.....	14
7.3.2. One-Shot Delay Adjustment.....	14
7.3.3. Setting the Threshold and One-Shot Delay Adjustment.....	15
7.4. Product Guide Adjustments.....	17
7.4.1. Width.....	17
7.4.2. Depth.....	17
7.4.3. Height Guides.....	18
7.4.3.1. Mechanical Height Guides.....	18
7.4.3.2. Air Guides.....	19
7.5. Centering the Counting Head.....	20
7.6. Bottle Shelf and Bottle Sensors.....	22
7.6.1. Bottle Shelf.....	22
7.6.2. Bottle Sensors.....	22
7.7. Funnels and Sieves.....	23
7.7.1. Funnels.....	23
7.7.2. Sieves.....	23
7.8 Testing to Establish Parameters.....	24
8. Counting and Filling.....	25
8.1. Preparation.....	25
8.2. Check Count Mode.....	25
8.3. Manual Mode.....	25
8.4. Automatic Mode.....	25
9. Cleaning – Breakdown and Buildup.....	26
9.1. Breakdown of Remove-To-Clean Contact Parts.....	26

- 9.1.1. Step-by-Step Breakdown – Upper Section and Head Section .....27
- 9.2. Buildup of Remove-To-Clean Contact Parts .....34
- 9.3. Clean-In-Place Contact Areas.....35
- 9.4. Non-Contact Areas .....35
- 9.5. Cleaning Recommendations.....35
- 10. Technical Information.....37
  - 10.1. Principle of Operation .....37
  - 10.2. Cycle of Operation .....38
  - 10.3. Troubleshooting .....39
  - 10.4. Index of Technical Notes/Drawings.....41  
(Technical Notes/Drawings Begin After Last Page)

## Section 1 - GENERAL ILLUSTRATIONS

### 1.1 FRONT VIEW

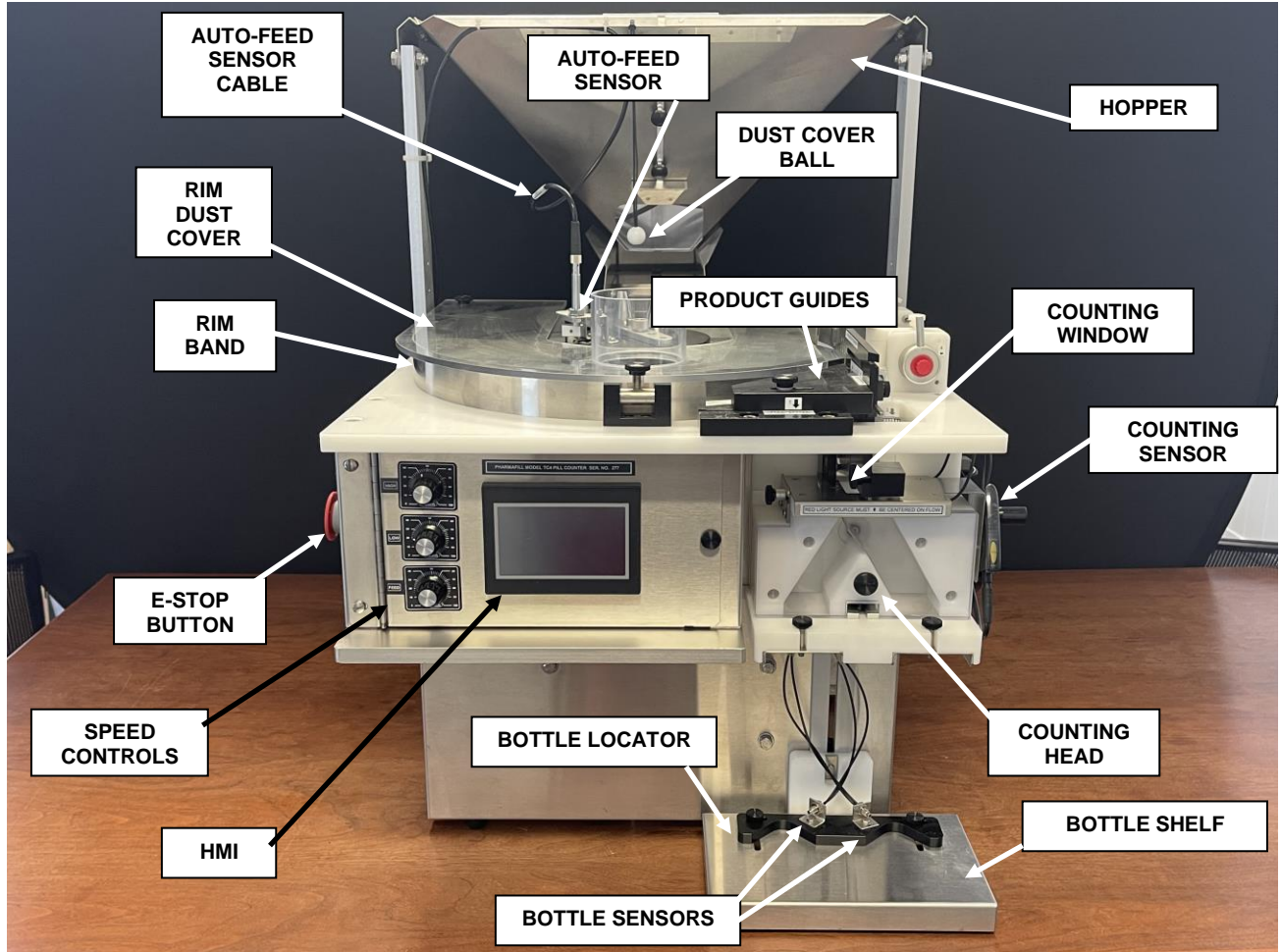

## 1.2 REAR QUARTER VIEW

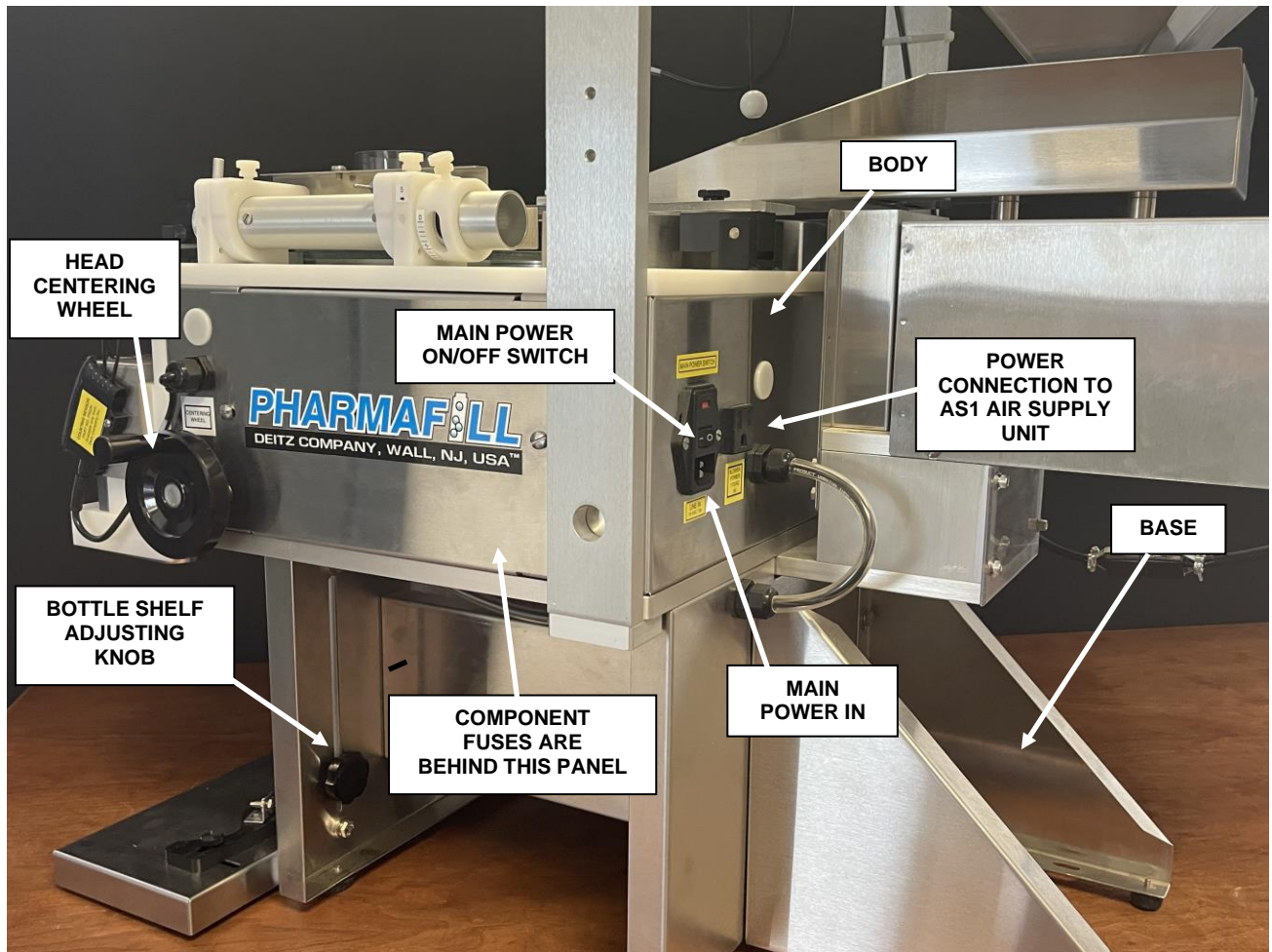



### 1.3 OVERHEAD VIEW

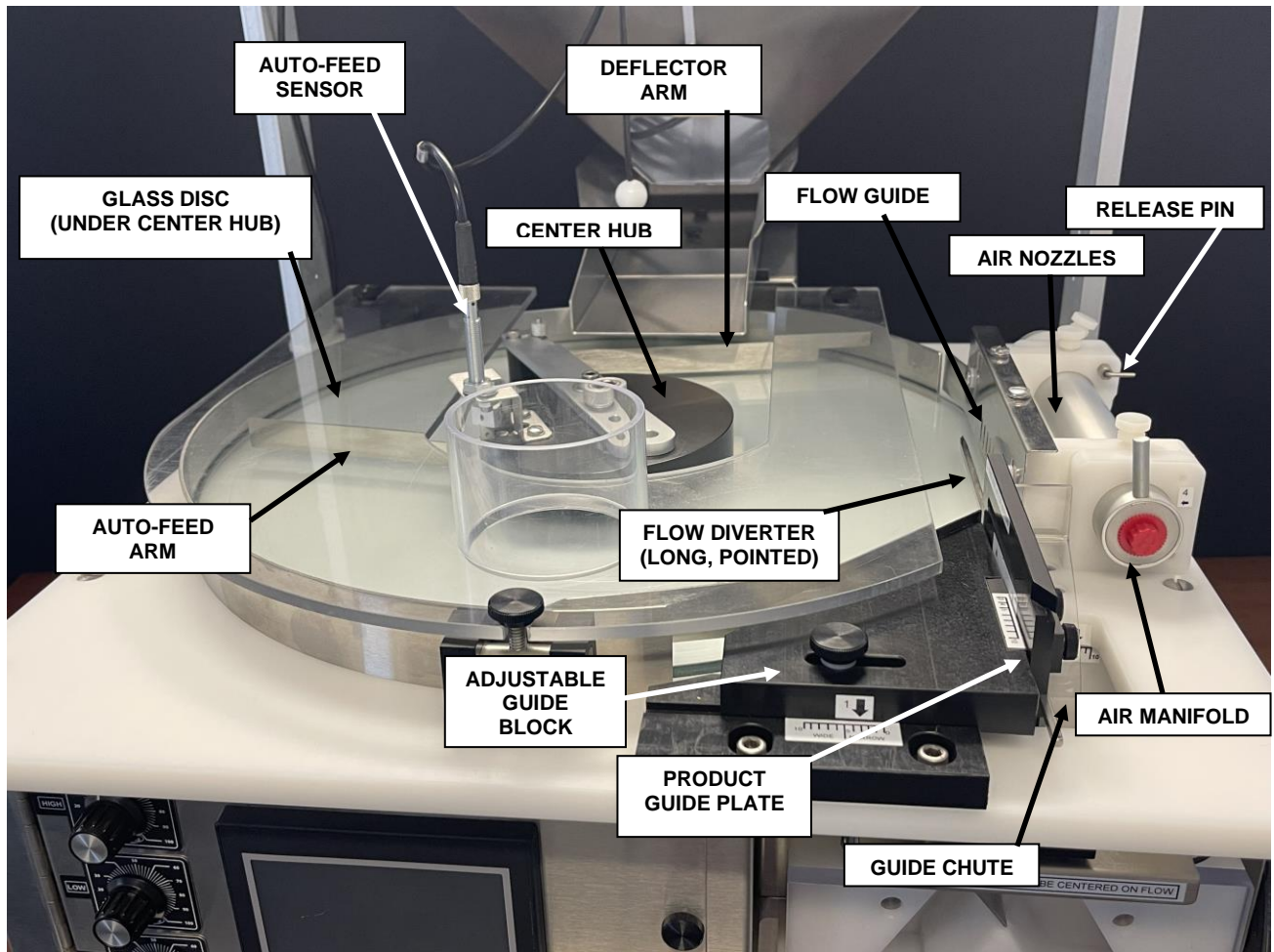

## 1.4 SIDE VIEW – STANDARD OPTIONS

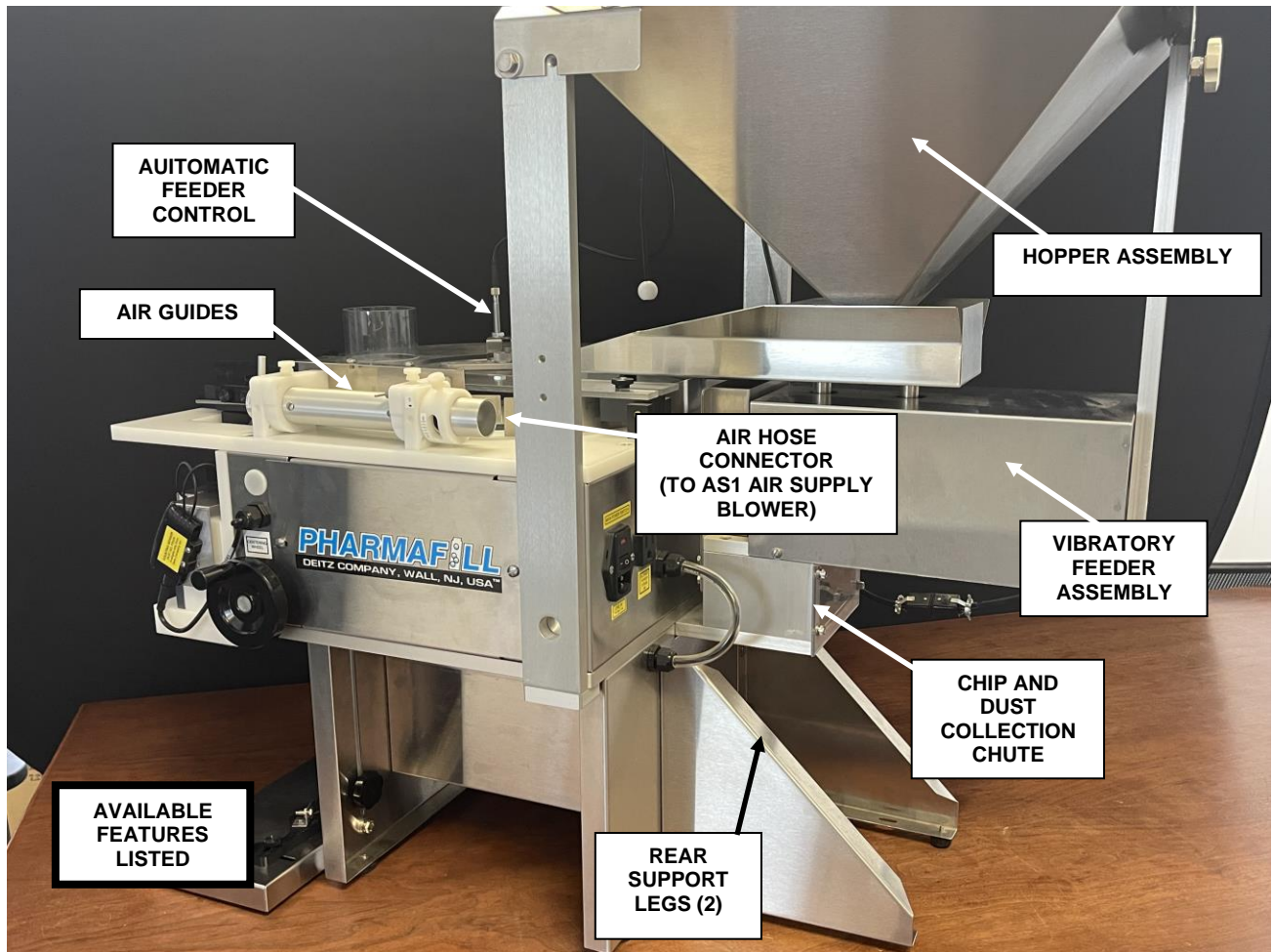

### Available Options:

1. Air Guide System
2. Include Air Manifold with Nozzles, Relief Ring and Air-type Flow Guide
3. AS1 Air Supply Blower (not shown)
4. Includes Air Hose
5. Vibratory Feeder Assembly
6. Includes Rear Support Legs
7. AFC Sensor - Automatic Feeder Control
8. Hopper Assembly
9. 6" Hopper Extension (not shown)

### 1.5 GLASS DISC, RING NUT, WASHER AND CLEAR RIM COVER

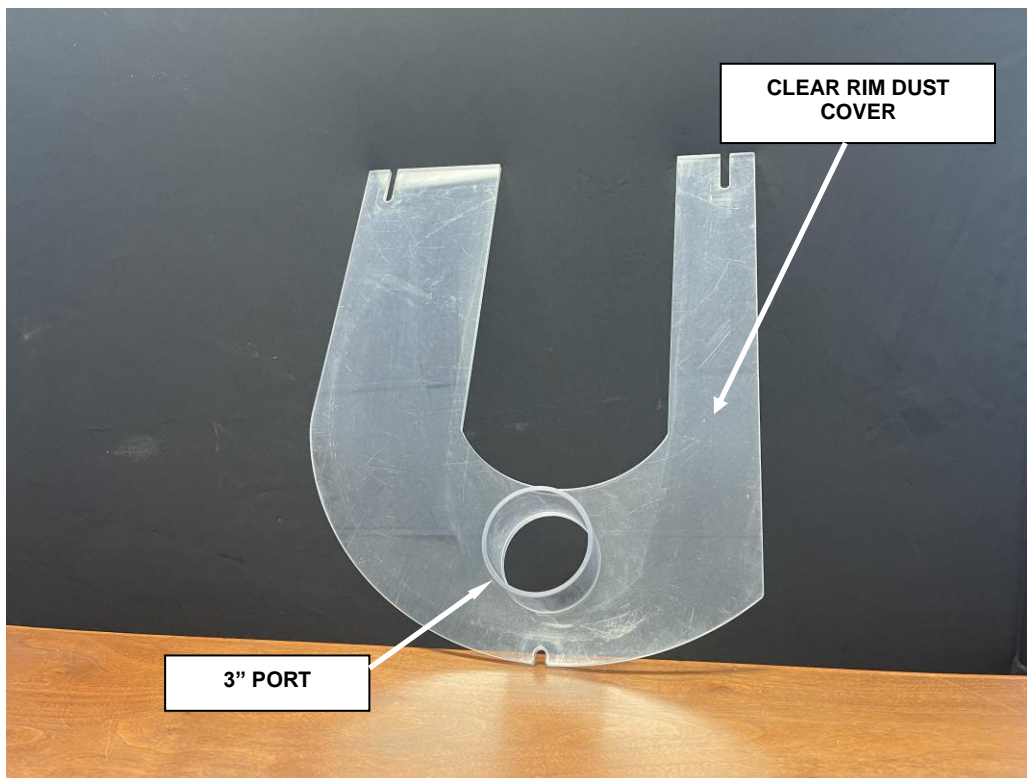
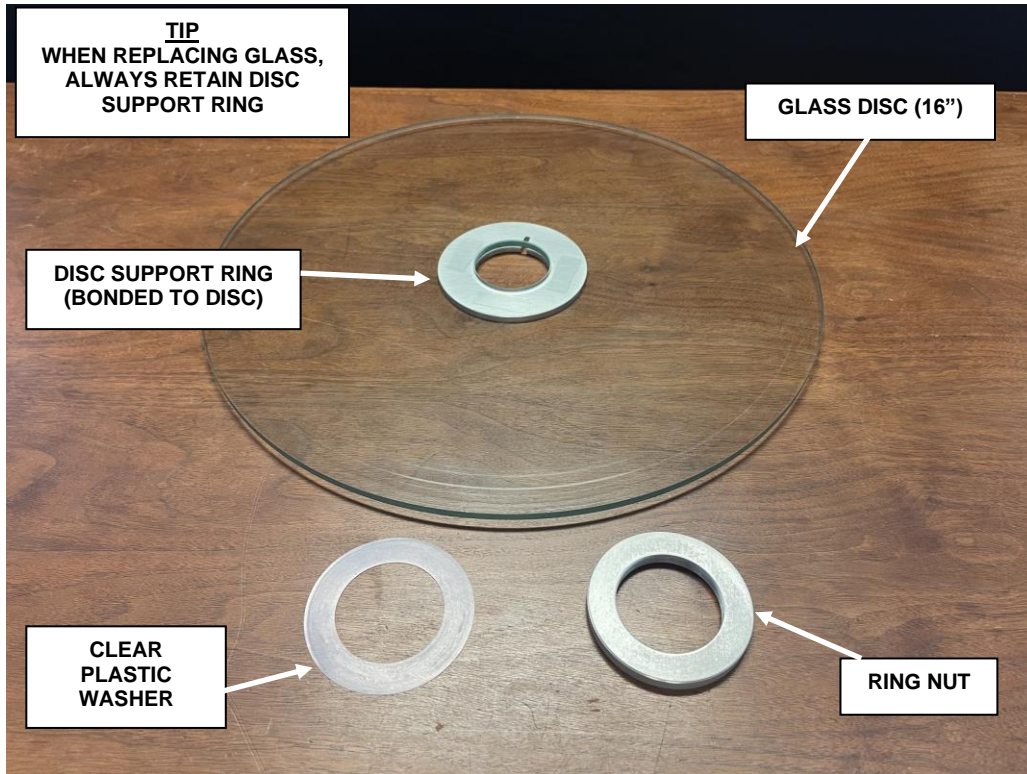



## 1.6 GUIDE BLOCK

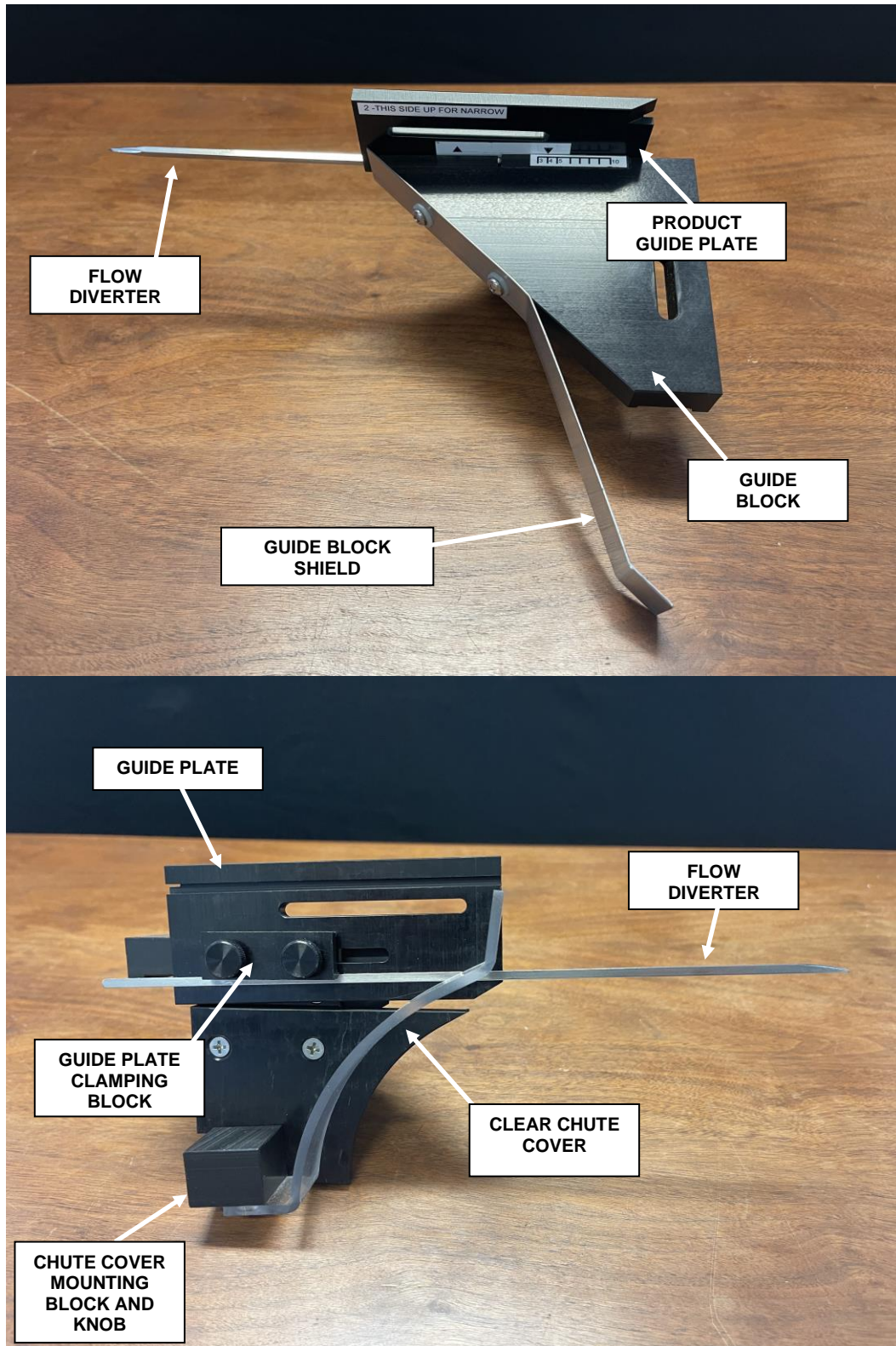

### 1.7 CENTER HUB, COUNTING HEAD PARTS

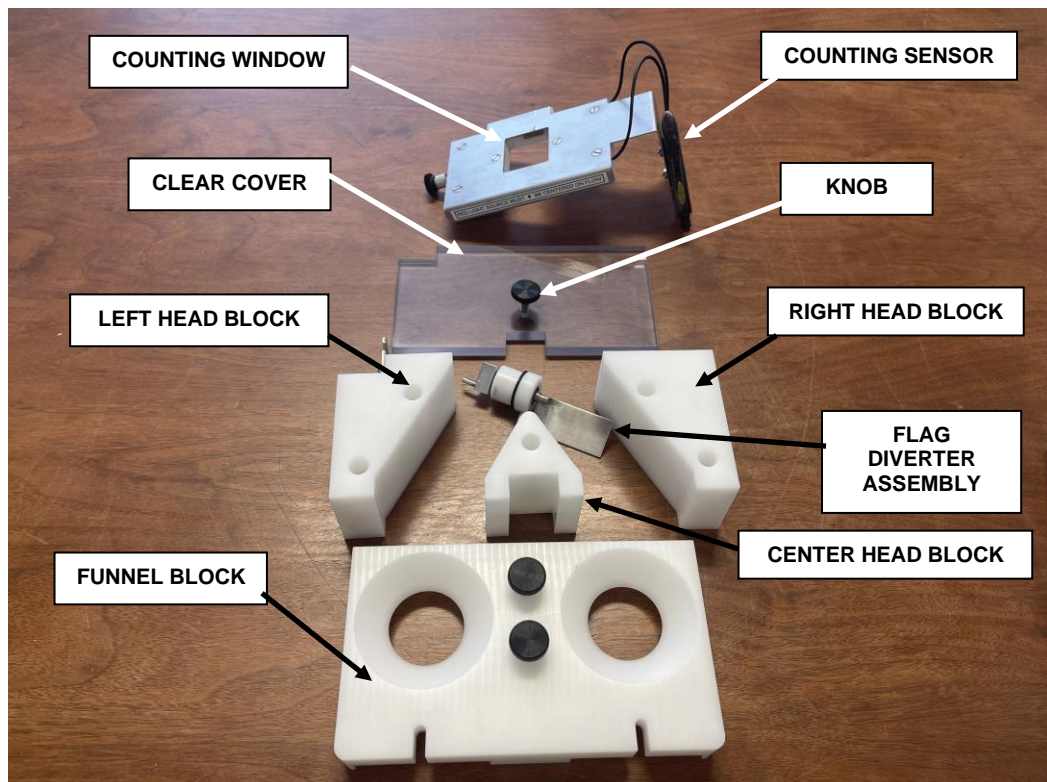
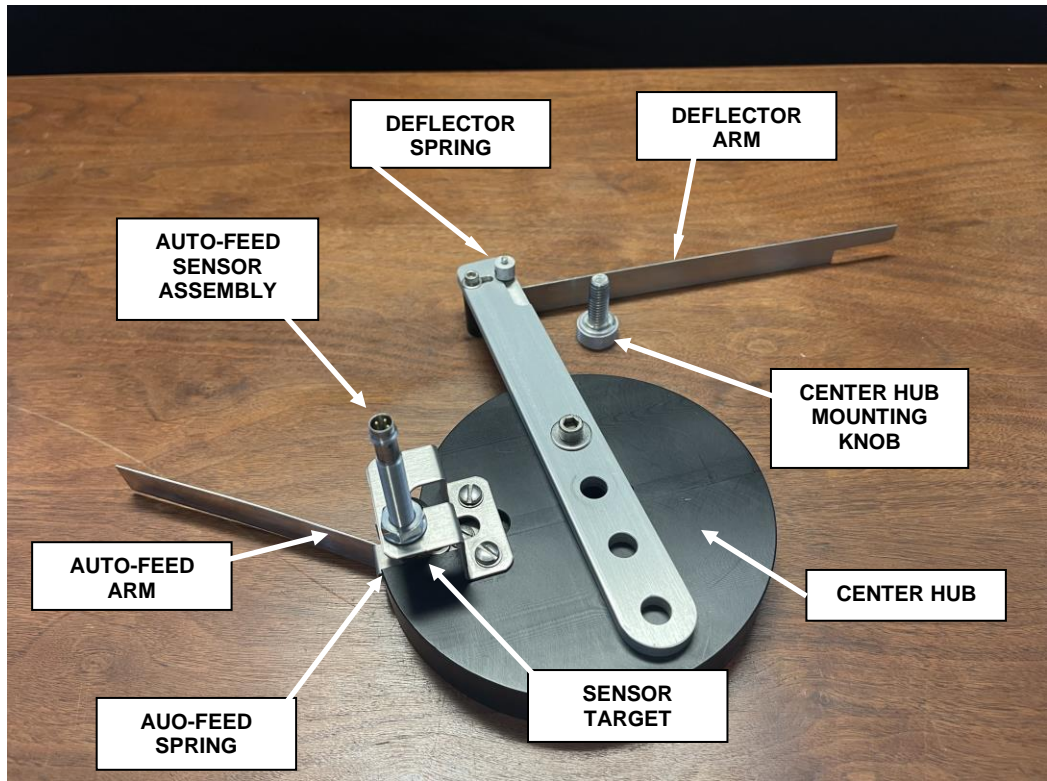



### 1.8 FUNNELS, HOPPER, FEEDER

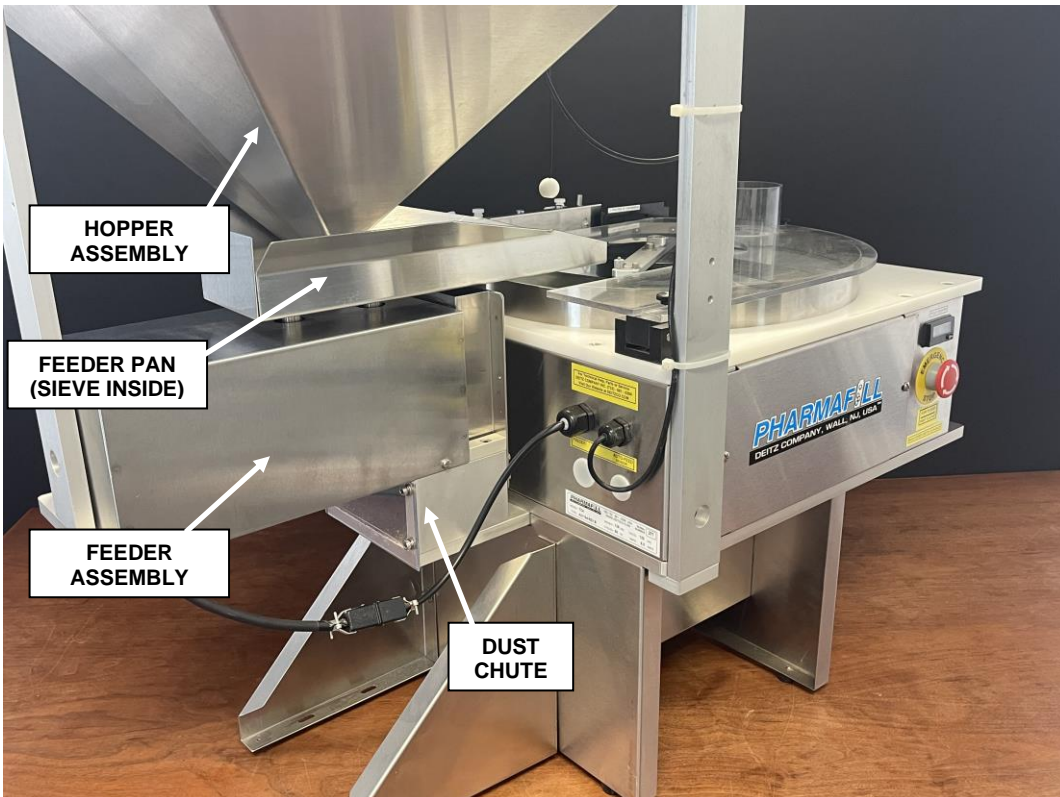
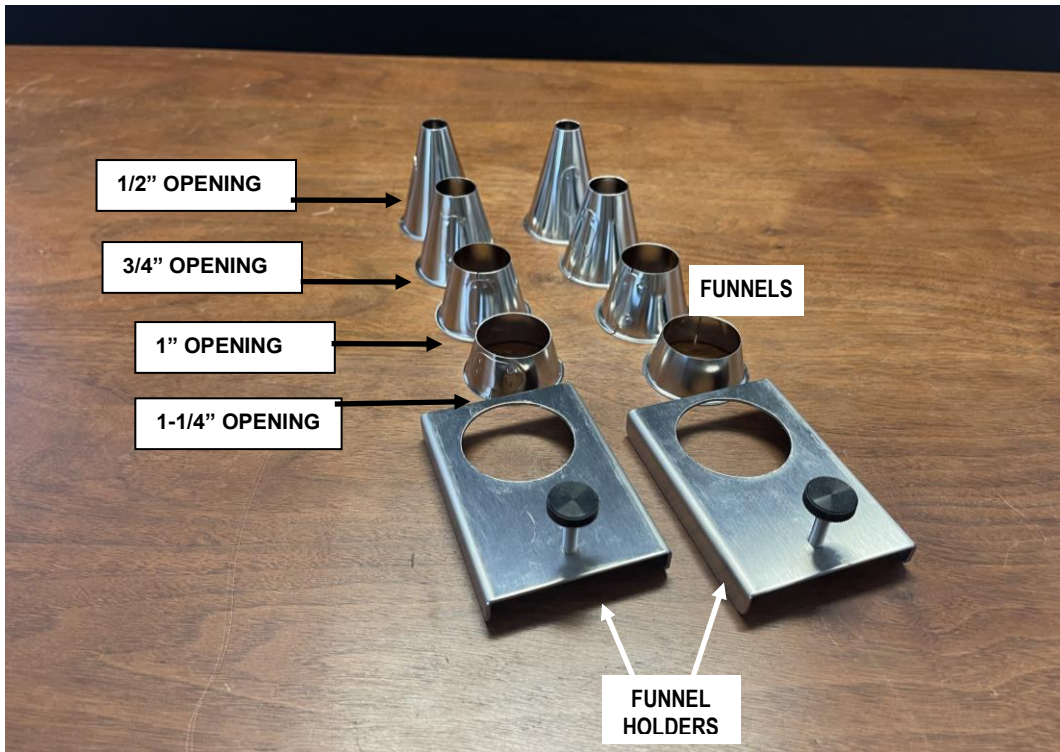

## 1.9 FEEDER PAN SIEVES

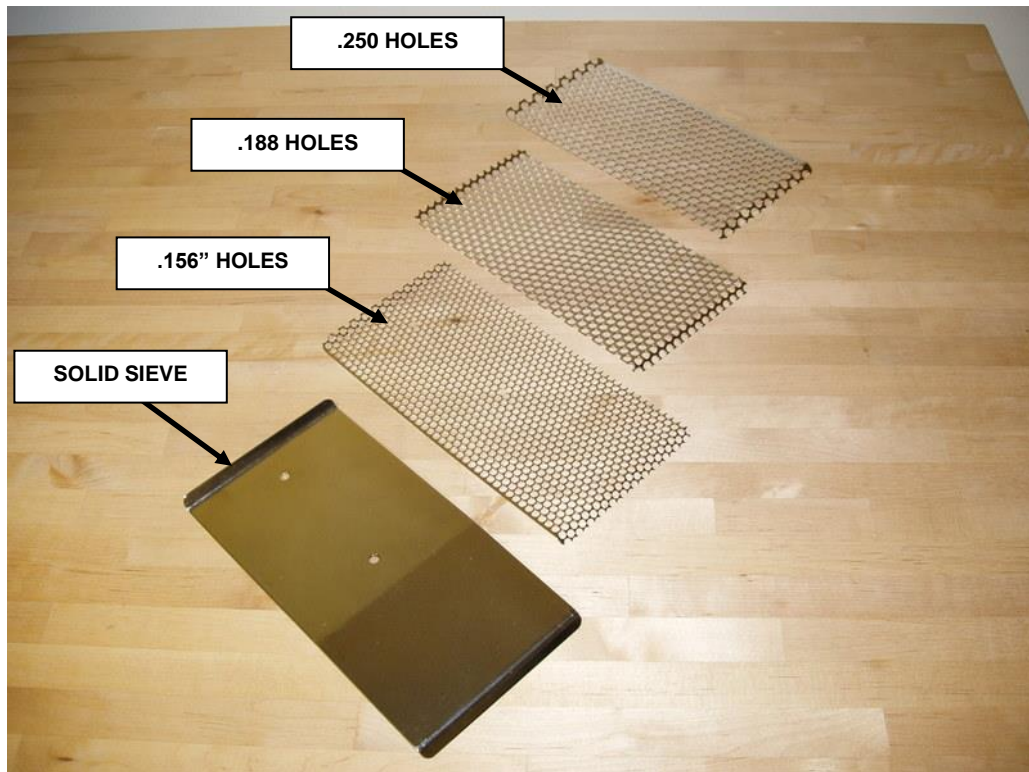



## SECTION 2 - SAFETY REMINDER



**Warning**



**This machine contains moving parts and operates automatically. This may present a hazard to personnel.**

**Never operate this machine with any covers or guards removed or any guard switches or safety devices removed or bypassed.**

**Only people who have been correctly trained should operate or clean this machine.**

**Only people who are correctly qualified and trained should carry out maintenance, installation or any other service work.**



**Never clean or service the machine without isolating the electrical supply and isolating the air supply.**



**Always test for the presence of voltage before touching or working on electrical components.**

**Note that there might be other requirements that could apply.**

**Refer to the manuals supplied by the component manufacturers for further safety instructions.**

## Section 3 - INTRODUCTION

Thank you for purchasing a Pharmafill Model TC4 Semi-automatic Pill Counter. We at Deitz Company hope you will find that the Model TC4 meets or exceeds your expectations and requirements for an affordable, reliable and innovative addition to your packaging operation.

Pharmafill products are designed and manufactured by Deitz Company Inc., in Wall, NJ, USA. We have manufactured machinery for the bottle filling industry since 1966 and started our Pharmafill line in 1993. We are a small (but growing) family-owned business that emphasizes quality, innovation and superior customer service.

If you have any questions or comments, please contact us by phone or visit our website. Chances are someone whose last name is Deitz will handle your inquiry personally.

Deitz Company Inc.  
PO Box 1108  
1750 Route 34  
Wall, NJ, USA 07719

Tel 732-681-0200  
Fax 732-681-8468

E-mail [sales@deitzco.com](mailto:sales@deitzco.com) or  
[sales@pharmafill.com](mailto:sales@pharmafill.com)

Web site [deitzco.com](http://deitzco.com) or  
[pharmafill.com](http://pharmafill.com)

The operation manual is designed to make it easier for you to know the machine and to make use of its intended range of operation. It contains important instructions on how to operate the machine safely, adequately and economically. Observing these instructions helps to avoid risks, to reduce cost for repair work and machine downtime, and enhances the machine's operational reliability and lifetime.

The operation instructions are to be supplemented by further instructions due to existing national regulations on accident prevention and environmental protection.

If used in compliance with the instructions contained in this manual and if safety devices are regularly maintained and properly working, this machine is not dangerous to the operator.

This manual is to be kept accessible to all operators using this machine and it is assumed that before use the operator will read fully and understand this manual and will follow instruction stated within.

### **Section 3 – INTRODUCTION (Cont'd)**

As this machine may be used in the packaging of hazardous substances the operator should be aware of the precautions required for these substances.

In addition to the operating instructions and the binding regulations on accident prevention valid in the country where the machine is being used and at its operational site, the recognized technical rules on safe and proper working must be observed as well.

These operating instructions and the information contained therein have been compiled with due care and attention. However, DEITZ COMPANY does not take any responsibility for misprints, translation errors or other errors and any damages resulting there from.

DEITZ COMPANY retains the right to make changes in the described products to improve functionality, reliability and design. The measurements or data shown on schematics, sketches and photos are not binding. They are for description purposes.

The information and drawings found in the operation manual are the intellectual property of DEITZ COMPANY and may not be copied or given to third parties.

LEGAL NOTICE: DEITZ COMPANY<sup>TM</sup>, PHARMAFILL<sup>TM</sup> and any graphic representations of the same are legal trademarks of Deitz Company Inc. and may not be used by others without specific written permission from Deitz Company.

## Section 4 – SPECIFICATIONS

(Also see technical information at end of manual)

### GENERAL

Model	TC4 Semi-automatic Pill Counter
Type	AD1154
Product Capability	Most solid oral dose tablets, capsules and caplets. Maximum width or diameter: 0.9 inch (22 mm) Maximum length: 0.9 inch (22 mm) Maximum height: 0.4 inch (10 mm)
Maximum Rate	Typical coated tablet, diameter .25 inch: 2500-3000 per minute Typical capsule, size 00: 1000-1500 per minute
Accuracy	Typically 99.99% (1 error per 10,000 pills) at optimal conditions

### INPUTS

Voltage	110 VAC <sup>1</sup>
Cycles	50/60 HZ
Phase	1
Amperage	2.0A with no outlet load or 7.0A with AS1 Air Supply Unit
Compressed Air**	Not required
Room Humidity	85% RH non-condensing

### DIMENSIONS

Floor Footprint	Base machine: 20.9" wide x 19.1" deep (53cm X 49cm) With Feeder/Hopper: 21.2" wide x 34" deep (54cm X 86cm)
Height	Base Machine 19.5" (50 cm) With Feeder 21.4" (54 cm) With Hopper 30" (76 cm)
Bottle Height	From 1" to 9" (2.5cm to 23cm) <sup>3</sup>
Weight	Base machine: 83 lbs (38 Kg) With Feeder: 113 lbs (52 Kg) With Feeder and Hopper: 120 lbs (58 Kg)

### OTHER

Hopper Capacity	0.6 cu. ft [.017 m <sup>3</sup> ], or 1.6cu. ft [.045 m <sup>3</sup> ] with 6" extension
Glass Disc	Float Glass 16" diam. X 1/4" thickness [40 cm x 6 mm]
Construction Materials	See Section 10.4 – Contact Compliance Document TC4-AD1154-CCD

#### Notes:

1. Other input voltages are available as factory options if specified at the time of order.
2. Compressed air, if supplied to air guide manifold, must clean and dry, free of moisture (water) and oil.
3. May be adjusted further by adjusting or modifying leveling feet.



## Section 5 - INSTALLATION AND COMMISSIONING

### 5.1 UNPACKING

- ❑ Carefully remove the cardboard cover from the pallet.
- ❑ Remove all packing materials any additional boxes that may be inside.
- ❑ Cut the plastic straps that hold the machine to the pallet.
- ❑ Position the machine on working surface (typically a table).
- ❑ Remove any shrink-wrap, bubble wrap and/or protective cardboard inserts.
- ❑ Inspect all supplied equipment for damage.
- ❑ If any damage is present, please notify DEITZ COMPANY immediately.
- ❑ Install the Head Centering Wheel (if removed for shipping). See the procedure on the following pages.
- ❑ **VERY IMPORTANT:** Refer to Section 9: “Cleaning – Breakdown and Buildup” to remove the last of the packing material and for cleaning prior to first use. **DO NOT** attempt to operate the machine before all packing material is removed before following this step.
- ❑ Connect electrical power and test. See the procedure on the following pages.

## 5.2 INSTALLATION OF THE HEAD CENTERING WHEEL



Remove the tape from the centering wheel shaft. Make sure the white plastic washer is in place.

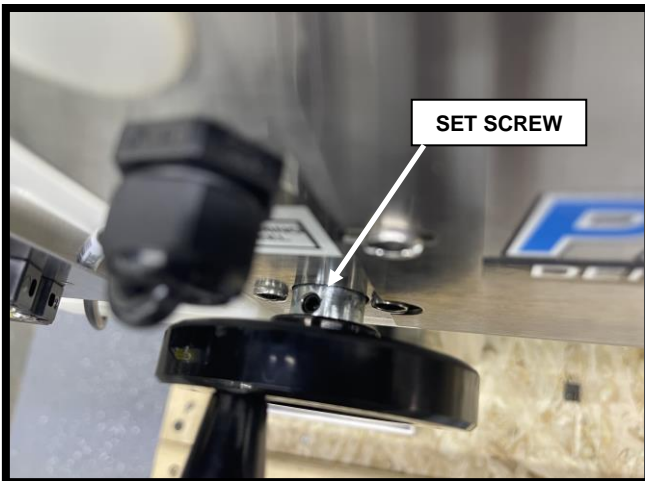

Use a 1/8" hex key to install the Head Adjusting Wheel. Make sure to align the setscrew in the wheel with the relief in the shaft.



Tighten securely.

**END 5.2**

### 5.3 ELECTRIC

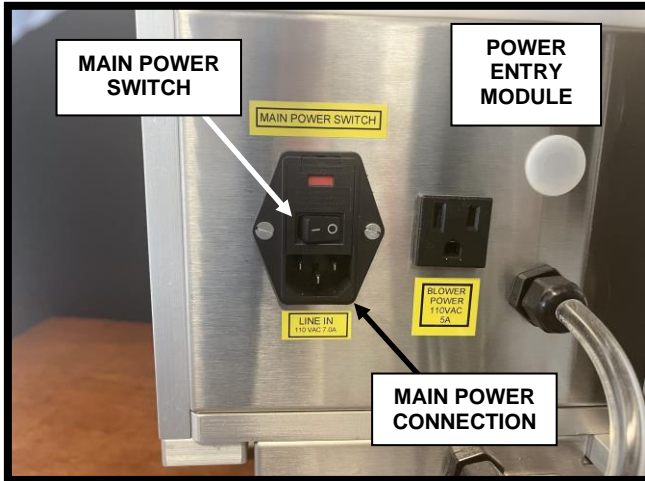

Locate the Power Entry Module at the rear of the machine. Make sure the Main Power Switch is in the OFF position (right).

Press the Emergency Stop button so that it latches in the “in” position.

Plug-in the provided power cord into the Power Entry Module. Plug the other end into a grounded 115 VAC outlet rated at no less than 10 amps.

**END 5.3**

## 5.4 CONNECT LOW PRESSURE AIR SUPPLY

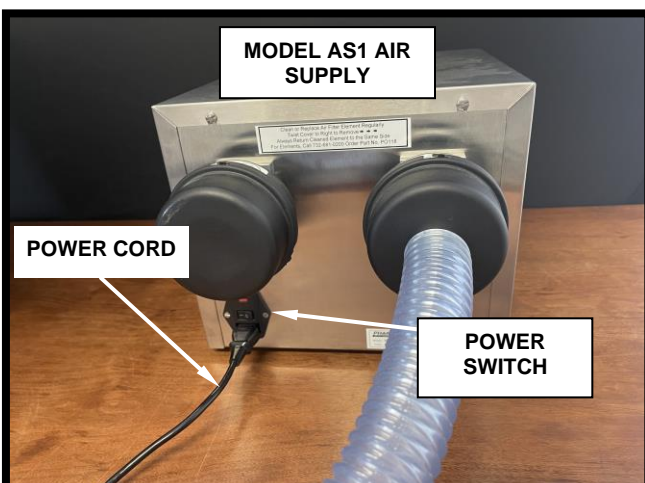
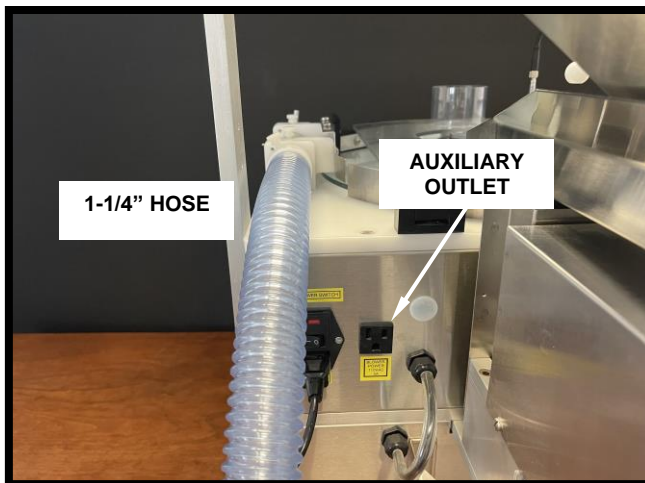
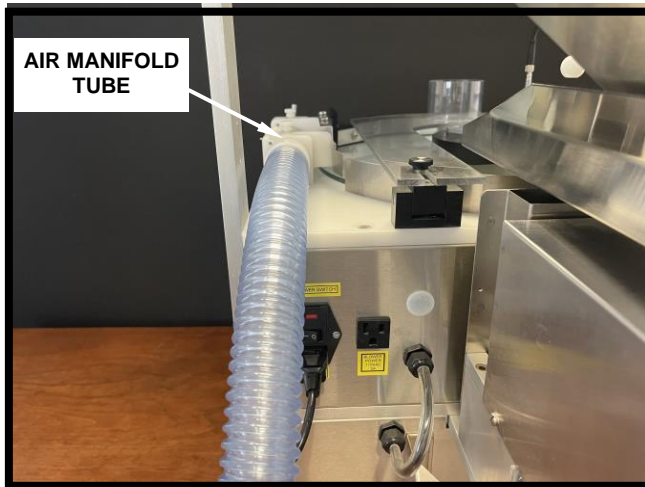

Attach the hose from the Model AS1 Air Supply to the 1-1/4" opening at the rear of the air manifold tube. Hose should fit snugly over air manifold (top photo) and Air Supply AS1 opening (bottom photo).

Plug the power cord from the AS1 Air Supply into the auxiliary outlet on the back of the TC4.

Turn on the AS1 at the switch on the power entry module of the AS1. It should not start running until the TC4 is turned on.

If using your own compressed air supply, attached your regulated line to the 1/4-NPT port at the rear of the air manifold tube.

**END 5.4**



## 5.5 SYSTEMS CHECK

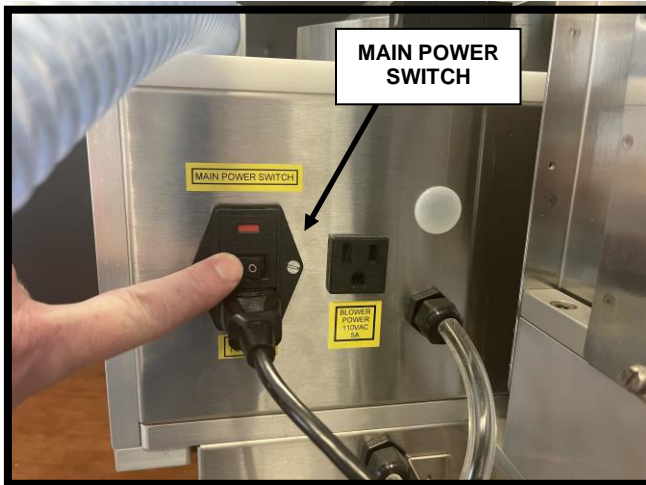

Turn on the machine at the Main Power Switch (left).

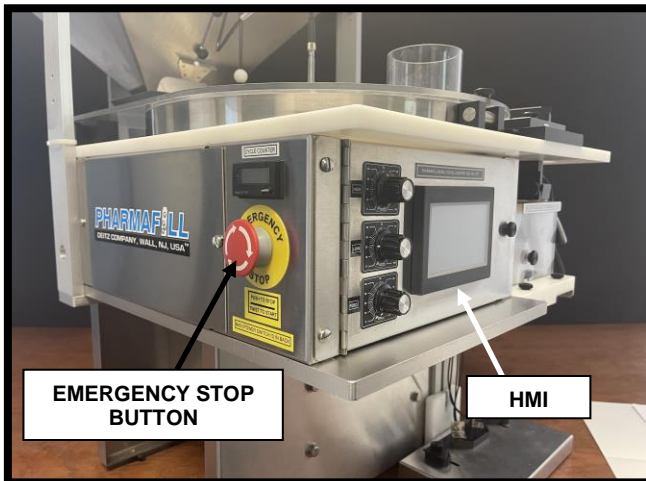

Twist and release the E-stop button. Confirm that the HMI lights up. After 5 seconds, the menu will appear on the HMI screen and the machine is ready to use.

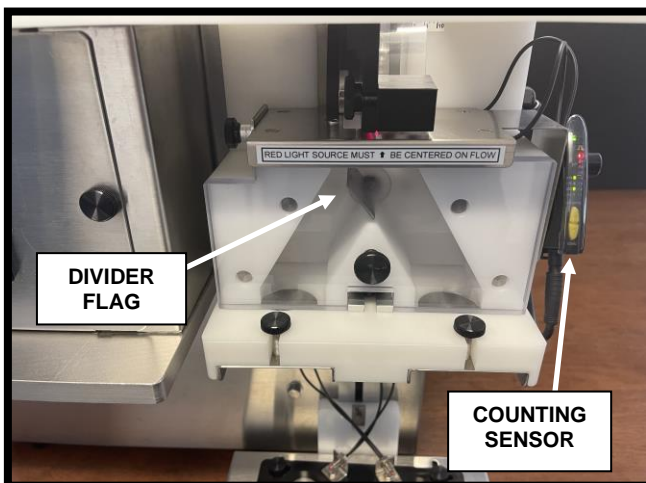

Confirm that the counting sensor lights up. Press the RESET button on the Control Panel several times and confirm that the divider flag flips back and forth smoothly and quickly.

**END 5.5**

## Section 6 - GENERAL INFORMATION

### 6.1 STANDARD FEATURES AND CAPABILITIES

The model TC4 Pill Counter is a rotating-disc electronic counter. The TC4 will count most solid oral dose products, including clear, translucent or center hole. It is designed to be easy to operate and maintain and is ruggedly built to stand up to hard use and last for decades.

The electronics inside include two computers (one in the PLC and one in the Counting Sensor), which are specially programmed to provide the most advanced features and performance.

The TC4 can be used for count verification, and manual or semi-automatic production filling.

- ❑ Check Counter – count the contents of a pre-filled and accurately
- ❑ Manual Production Filler – fill one container with a pre-set quantity.
- ❑ Semi-Automatic Production Filler – continuously fill one container after another, with an operator providing empty bottles and taking away filled ones.

### 6.2 RECOMMENDED FEATURES

The TC4 can be built to the customer requirements. Machines may be upgraded in the field.

- ❑ Air Guide System – replaces the basic mechanical height guides with an adjustable air jet, allowing easy setup from one product to the next, and jam-free product flow. Available with our AS1 Air Supply unit for clean, quiet low-pressure air.
- ❑ Feeder With Chip Collection Chute – variable speed vibratory feeder with tray. Includes sieves plates and a dust chute to collect dust and chips. The operator fills the tray with a supply of product, which is fed onto the glass disc at a controlled rate. This saves the operator from manually feeding the product directly onto the disc.
- ❑ Automatic Feeder Control – a special sensor assembly, which turns the feeder on only when more product is need on the disc. This way the feeder will always provide the correct amount of product, with over-feeding or starving the disc.
- ❑ Hopper – holds a large supply of product (up to 10,000 pieces) with adjustable opening and visual sight indication of level. Product is fed into the vibratory feeder tray. Ideal for semi-automatic production.
- ❑ Hopper extension – allows for an additional 6” of height on Hopper

## SECTION 7 - OPERATION

### 7.1 CONTROL PANEL COMPONENTS

The Control Panel has two sections – Speed Controls and HMI (Human-Machine Interface)

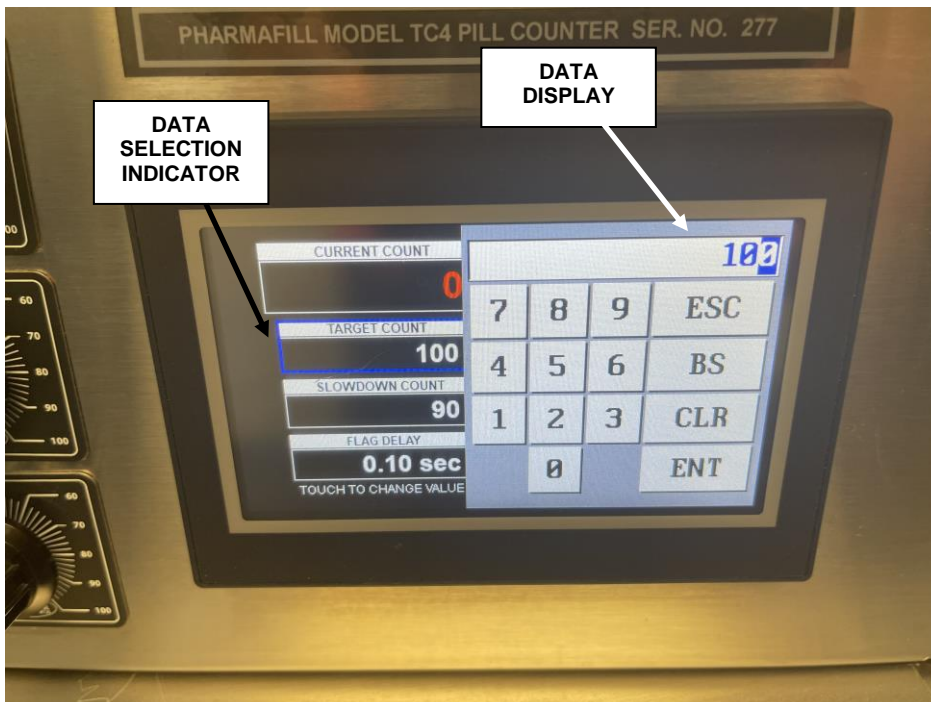
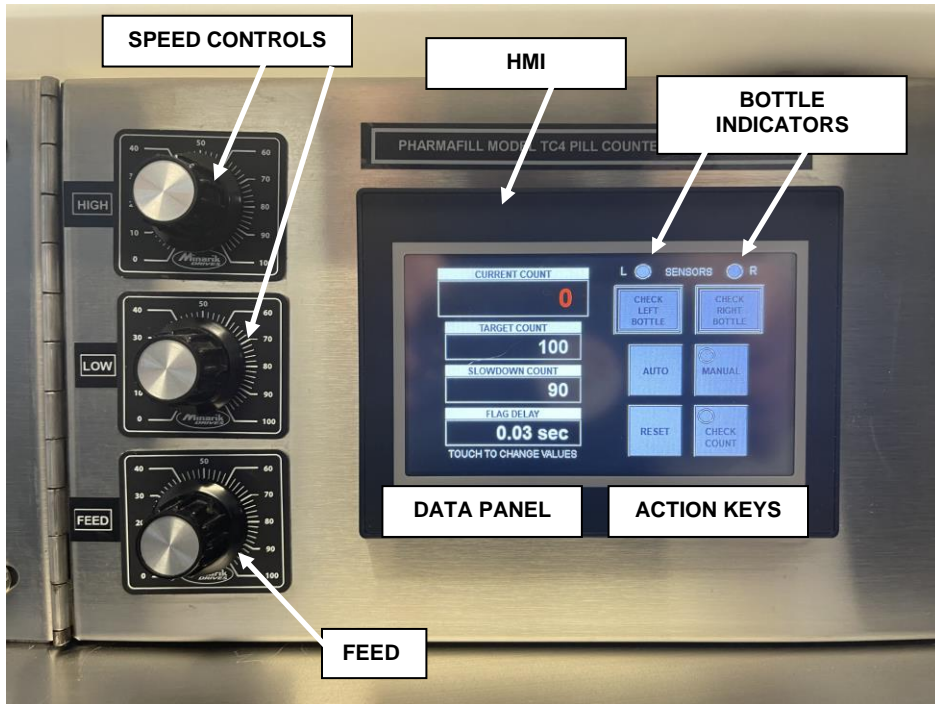

### 7.1.1 HMI DATA SECTION

The data section controls four numeric values:

<u>Value</u>	<u>Type</u>	<u>Range</u>
Current Count	Display only	0-9999
Target Count	Adjustable	0-9999
Slowdown Count	Adjustable	0-9999
Flag Delay	Adjustable	0.0 - 0.09 seconds

The Data Display shows a 4-place number. The Data Selection Indicator shows which value is being displayed. The Data Display lets you change the value (where possible).

To view or change the data, press the desired Data Key and the Data Display window will appear. ESC will return to the menu without making changes. BS will remove one numeral at a time. CLR will ZERO all numbers. Change the value using the numeric keys. Press ENTER to accept changes.

**CURRENT COUNT** - (display only) the total number counted since the last reset. The maximum display value is 9999. It cannot be adjusted, except with the Reset key (next section), which forces the value to zero.

**TARGET COUNT** - (adjustable set point) the desired number per container. The maximum value is 9999.

**SLOWDOWN COUNT** - (adjustable) the number of items to be counted to cause the disc to slow down as the Target Count is approached. The maximum value is 9999. The value must be less than the Target Count.

**FLAG DELAY** - (adjustable) a time delay between the moment the Target Count is reached and when the flag flips. This is to allow enough time for the target count pill to fall from the counting window to the divider flag. The maximum set point value is 0.09 sec. Generally, the usable range is 0.0 to 0.05 sec.

### 7.1.2 HMI ACTION KEYS

The four action keys are marked AUTO, MANUAL, RESET and CHECK COUNT.

**AUTO** – (Alternate ON/OFF) This is the production-filling mode. Press AUTO to start the disc (and feeder, if equipped) to begin delivering product. The machine will now continuously count product, alternately discharging to the right or left funnel. Containers must be continuously supplied and removed in sync with the machine. Press AUTO again to stop or press the RED E-STOP BUTTON on the left side.

**MANUAL** – (Momentary ON) This is used to fill one container at a time manually. Press to start the disc (and feeder, if equipped) to begin delivering product until the target



count is reached one time. Product delivery will stop, the flag will flip, and the counter will reset. After the reset, any product that runs on is counted and discharged to the alternate funnel. Press again to repeat. Good for parameter testing, check counting and casual production filling.

**RESET** – (Momentary ON) Press to immediately set the Current Count to zero and flip the divider flag. In manual mode, counting will stop. In Auto or Check Count modes, counting will continue.

**CHECK COUNT** – (Alternate ON/OFF) This mode will count continuously without flipping the divider flag. The Target Count and Slowdown Count are ignored. Press to begin delivering product and counting. Counting will continue until you press the button again. In Check Count mode, the maximum count is 99,999,999, although the display will only show the last four numerals.

### **7.1.3 BOTTLE INDICATOR SENSORS – LEFT, RIGHT**

The two indicators are marked as follows:

**FILLING LEFT** – indicates the divider flag is positioned to direct product to the left funnel. There should be a container on the left side of the bottle shelf to catch the product.

**FILLING RIGHT** – indicates the divider flag is positioned to direct product to the right funnel. There should be a container on the right side of the bottle shelf to catch the product.

## **7.2 SPEED CONTROLS**

Speed controls (potentiometer adjustment knobs) are located on the left side of the control door. All machines have two control knobs for the speed of the glass disc, marked **HIGH** and **LOW**. Those equipped with the vibratory feeder have a third control knob, marked **FEED**.

The glass disc runs at two speeds, changing from high speed to low speed as the target count is approached.

**HIGH** – This is the speed of the disc when the Current Count is less than the Slowdown Count. This should be set up to the highest speed at which a particular pill can be counted with the required accuracy. While this speed may be good for counting, it may be too fast the Divider Flag to precisely split the flow when the target count is met. This speed is found by running test counts.

**LOW** – This is the speed of the disc when the Current Count is greater than the Slowdown Count. This should be set to the speed at which the Divider Flag can split the flow precisely. This speed is also found by running test counts.

FEED – This controls the feed rate of the product from the vibratory feeder to the glass disc. The feeder will stop when there is an adequate supply of product on the glass disc. As the supply diminishes, the feeder will resume feeding.

### 7.3 COUNTING SENSOR

- ❑ Detects solid (opaque) product and translucent or clear product, such as gel caps.
- ❑ Automatically and continuously adjusts light level for maximum sensitivity
- ❑ Compensates for dust buildup and sets alarm if conditions become marginal.

#### 7.3.1 THRESHOLD ADJUSTMENT – How Much the Light Level Must Drop to Count.

When the light in the counting window is unblocked, the sensor detects 100% of the light. When an object falls through the window, the light is blocked. If the threshold size is set to 40%, the sensor will send a count signal when 40% of the light is blocked; that is, when the light level falls below 60%. The sensor will reset when the light level rises above 60% again. This is the factory setting and works with most products. The threshold can be reduced to as low as 5%.

Adjustable in 5% increments

Light bar 1=5%

Light bar 8 = 40% (factory setting, most products)

- THRESHOLD FACTORY SETTING = 8 (good for all but the smallest pills)

#### 7.3.2 ONE-SHOT DELAY ADJUSTMENT – How Long the Count Signal Stays On.

This is a feature for CLEAR PRODUCT ONLY. It is used to stretch the count signal so a product with a clear center does not produce a “double” count. Normally set at the minimum (5 ms) for solid product. For clear or opaque product, increase the one-shot according to the length of the product. For example, 10 ms for round gel caps .25” long, or 40 ms for oblong gel caps .90” long.

Adjustable in 5 millisecond increments

Light bar 1 = 5 ms (factory setting, for solid product)

Light bar 8 = 40 ms (for long clear products)

- ONE-SHOT DELAY FACTORY SETTING = 1 (good for all solid product)
- ONE-SHOT DELAY 2-8 is for CLEAR PRODUCTS ONLY
- With ANY product, if the ONE-SHOT DELAY is set too high, it will cause OVERFILLS (too many pills in the bottle)
- With CLEAR product, if the ONE-SHOT DELAY is set too low, it will cause UNDERFILLS (too few pills in the bottle).

### 7.3.3 SETTING THE THRESHOLD AND ONE-SHOT DELAY ADJUSTMENTS

THRESHOLD (Factory setting = 8)

To adjust:

- Press and release + (plus)
  - Light bar will change to indicate current threshold
  - “LO” and “DO” lights will flash alternately
- Press + to increase the threshold (less sensitive)
- Press – to reduce the threshold (more sensitive)

Will automatically exit adjustment mode after 4 seconds of inactivity

Will automatically reset light level for maximum performance before returning to normal.

ONE-SHOT DELAY (Factory setting = 1)

To adjust:

- Press and release – (minus)
  - Light bar will change to indicate current one-shot delay
  - “Clock” light will flash
- Press + to increase the one-shot delay.
- Press – to reduce the one-shot delay.

Will automatically exit adjustment mode after 4 seconds of inactivity

Will automatically reset light level for maximum performance before returning to normal.

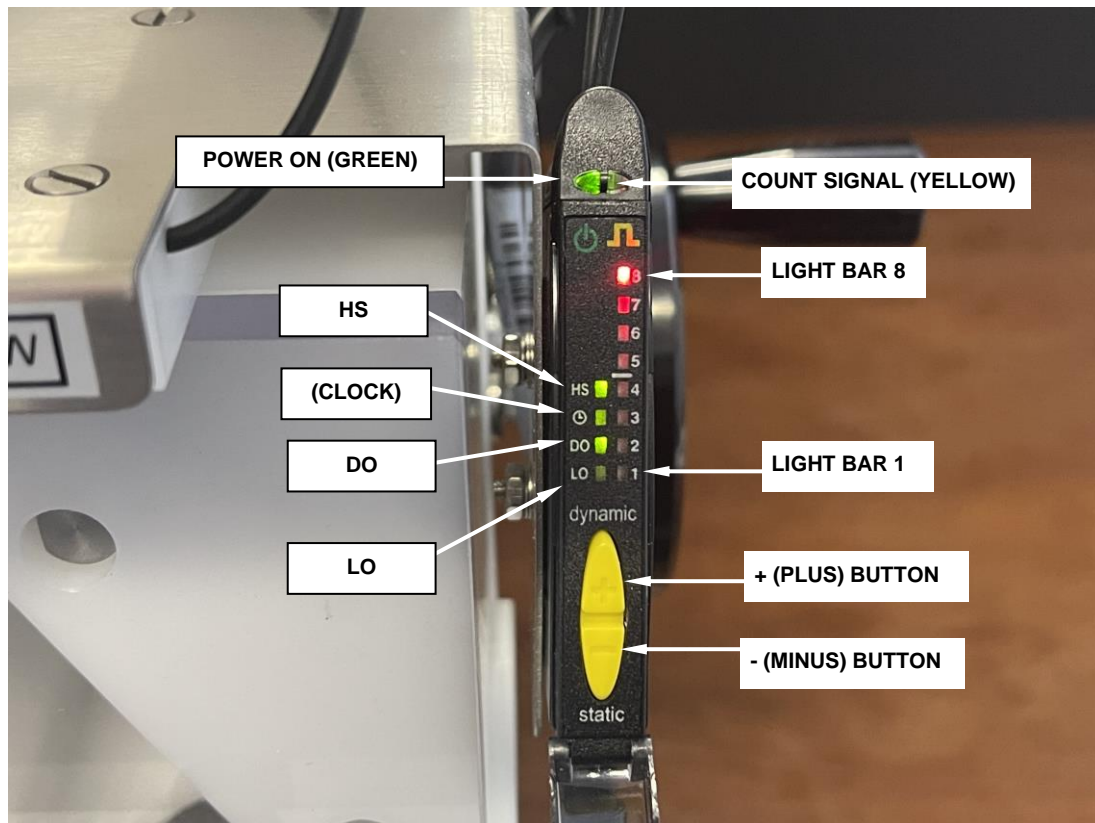

This page intentionally left blank.

## 7.4 PRODUCT GUIDE ADJUSTMENTS

The guide adjustments create a steady flow of product down the channel, into the chute and through the center of the counting window. The flow must be single file, one level high.

### 7.4.1 WIDTH

The channel width is adjusted by moving the Guide Block Assembly side-to-side. To adjust, loosen the knob and move the guide block to the left. Place a few pills in the channel and move the guide to the right so that only a single file row may pass down the channel. Leave enough room so that the product will flow freely. Tighten the knob. NOTE: if the guide block will not open fully, check that the Guide Plate depth is not limiting the travel.

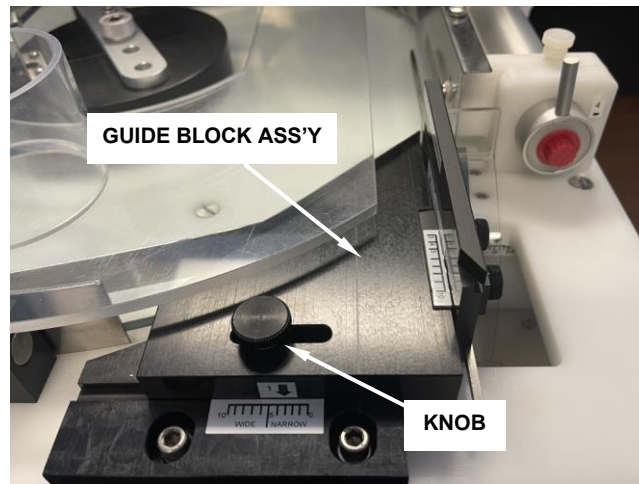

### 7.4.2 DEPTH

The Guide Plate is kept close to the edge of the glass disc by the depth (front-to-back) after the width is set. Loosen the two knobs on the Guide Plate just enough to move the plate. Slide it forward until it touches the edge of the glass disc, and then move it back a bit so that it does not drag on the disc (adjust for minimum clearance). As you tighten the two knobs, rotate the Guide Plate forward so that the pointed tip of the Flow Diverter is lightly touching the glass disc.

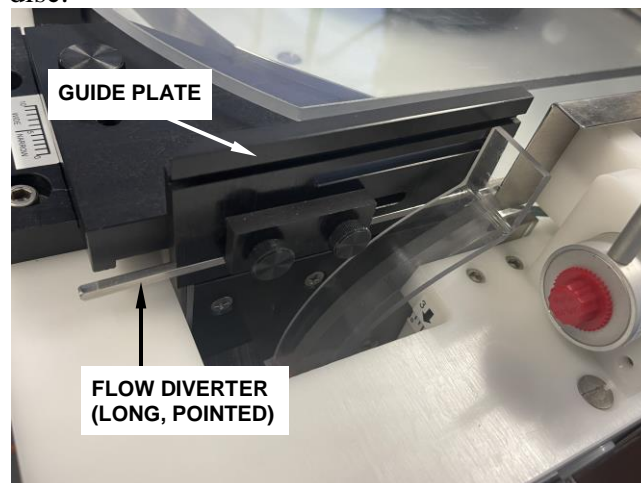



### 7.4.3 HEIGHT GUIDES

The mechanical height guides or the air guide must be set to reject certain faults, such as a pill in the channel traveling on top of another pill (doubles), leaning up against another pill (piggy backs) or riding on edge (standups).

Tip: The setting of the either type height guide can best be fine-tuned while the product is flowing, when you are making test runs.

#### 7.4.3.1 MECHANICAL HEIGHT GUIDES

For tablets, use the adjustable Height Block (triangular block at entrance to channel) to prevent faults. Loosen the knob on the bracket and set the guide slightly higher than one tablet laying flat. Move the Capsule Wire out of the way.

For capsules and caplets (caps), use the Capsule Wire (spring wire midway down the channel) to prevent faults. First, raise the Height Block up out of the way, since caps usually wedge under against a rigid guide. To set the Capsule Wire, loosen the knob and set the guide slightly higher than one cap laying flat. The cap guide may also be rotated or bent to better reject the doubles.

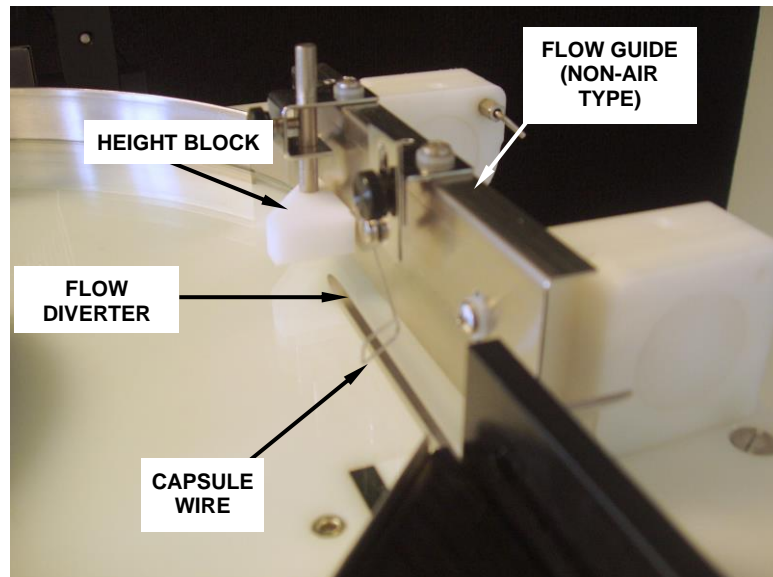

### 7.4.3.2 AIR GUIDES

The Air Guides work for all types of products (tabs, caps, etc.). They prevent jams better than mechanical guides, are easy to adjust and are not prone to stoppages that require an operator to clear.

To set the Air Guides, loosen the knobs on the air guide blocks. Use the handle on the air manifold to rotate the Air Jets so that the air flows just above the pills in the channel. If set too low, the air will disturb the flow in the channel, impeding the flow and possibly blowing pills right out of the channel. If set too high, faults might not be rejected. Once set at the right height, tighten the knob.

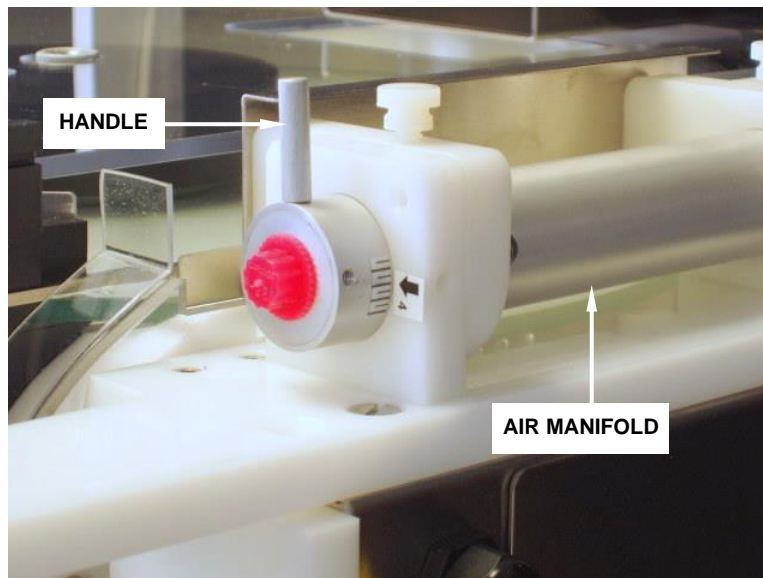
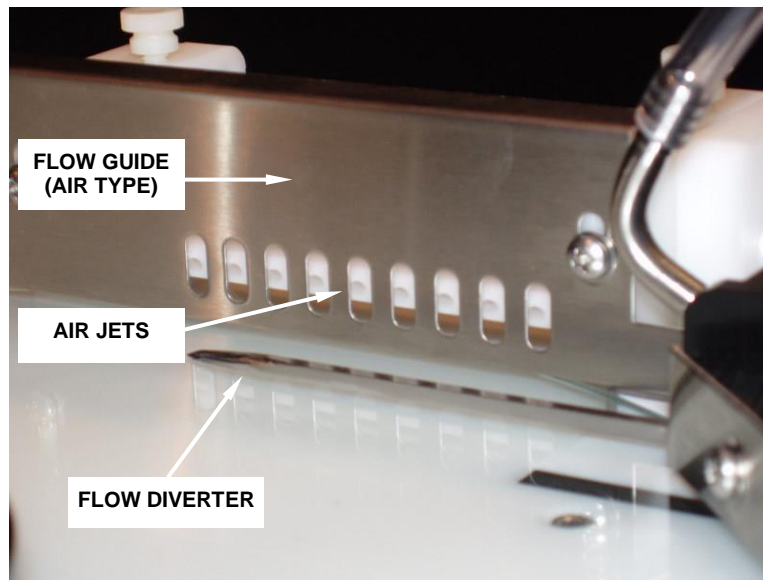

## 7.5 CENTERING THE COUNTING HEAD

To count properly, objects must fall directly from the chute into the center of the counting head. This way the object will fall through the center of the light source of the counting window and strike the divider flag at the same angle whether filling right or left

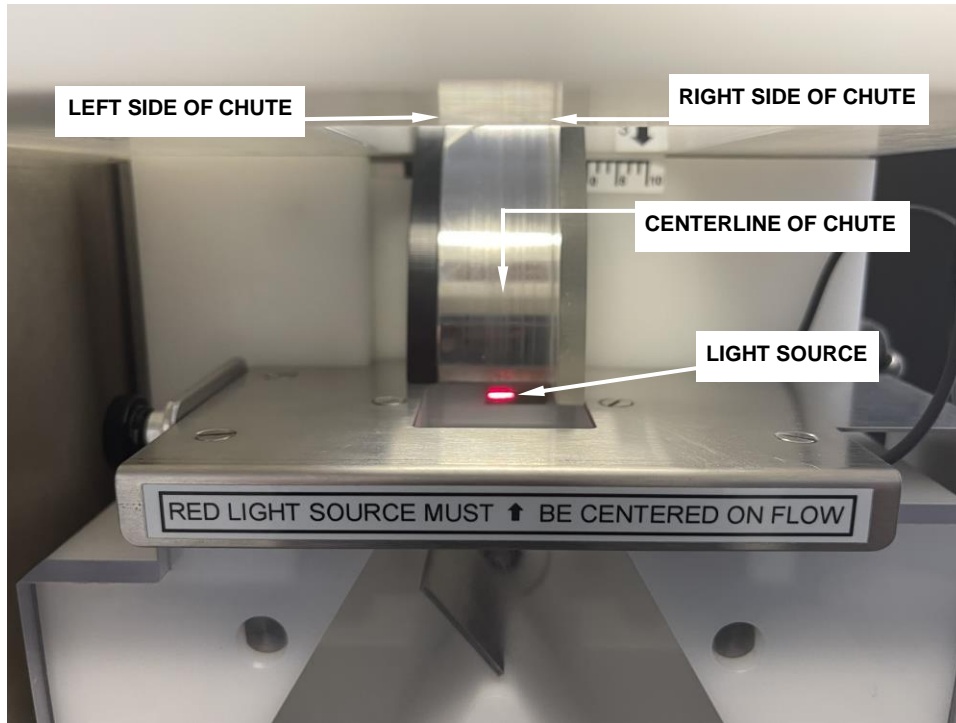

When you make a change to the width of the product guide assembly, you are moving only the left side of the chute. This changes the location of the centerline, so you must also adjust the counting head. Do this by turning the centering wheel on the right side of the machine.



Once you have visually confirmed that the Counting Head is centered on the chute, note the position of the head relative the scale and arrow located in the opening by the chute.

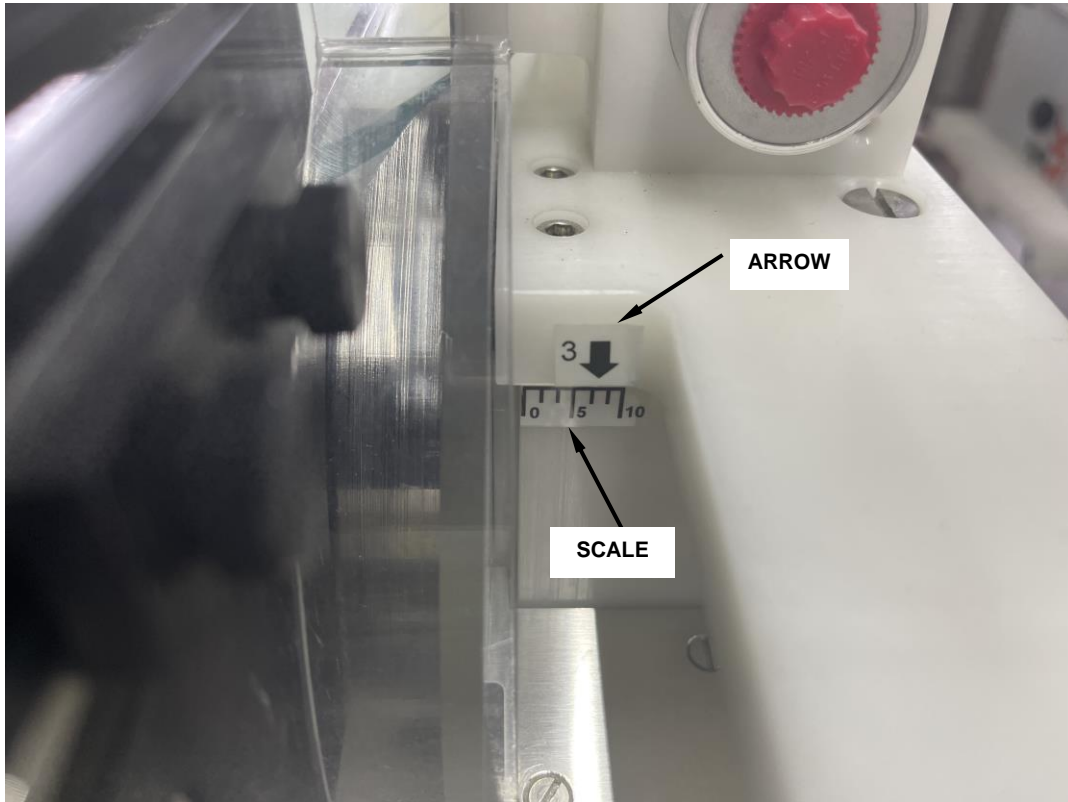

## 7.6 BOTTLE SHELF AND BOTTLE SENSORS

### 7.6.1 BOTTLE SHELF

Adjust the height of the Bottle Shelf by loosening the Locking Handle and moving the shelf up or down. Adjust the Bottle Locator front-to-back to properly center the container opening on the funnels.

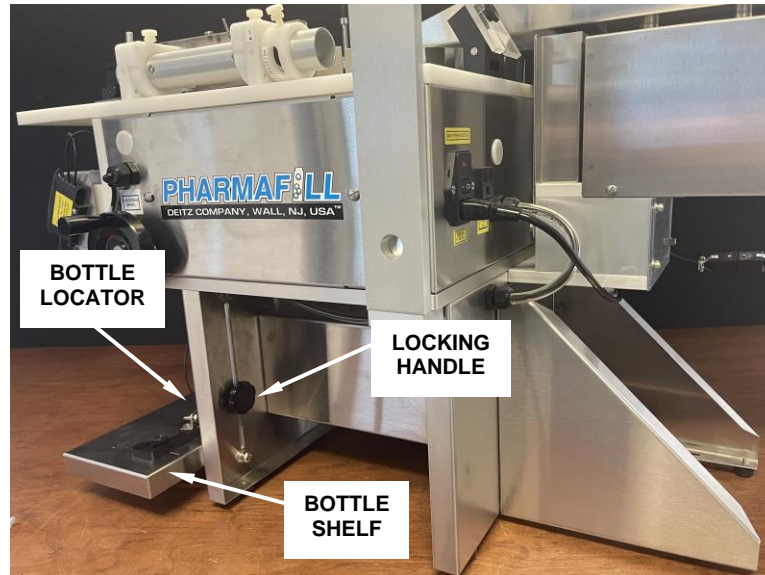

### 7.6.2 BOTTLE SENSORS

Fiber-optic sensors detect bottles within their range of view. Once filling is complete on one side, the flag diverter flips and begins filling the other side. During this time, the operator must remove the filled bottle and replace it with an empty one. Once the slowdown count is exceeded, filling will stop if the opposite side 1) has no bottle or 2) has a filled bottle that was not replaced. Filling will resume when the operator replaces the bottle on the opposite side.

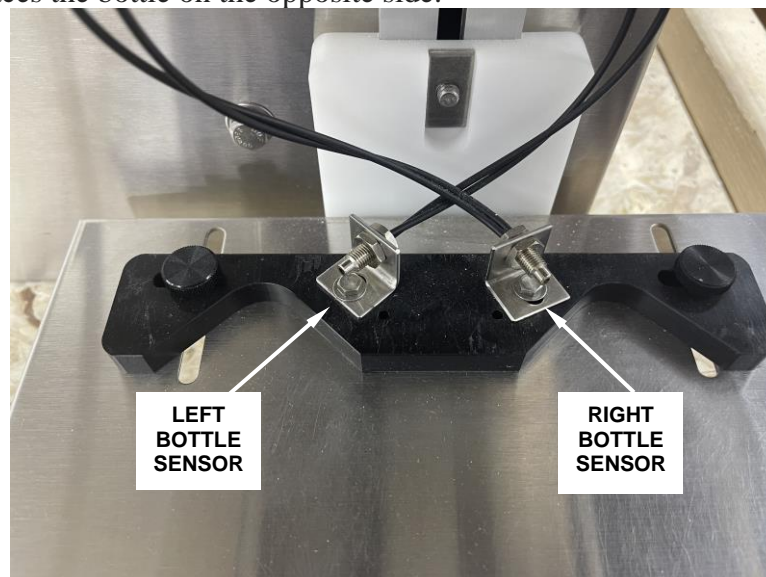



## 7.7 SIEVES AND FUNNELS

### 7.7.1 SIEVES

A sieve consists of a housing containing a removable wire mesh of a defined aperture size. This assembly is vibrated by an electric motor so that small particles or broken tablets can pass through the mesh apertures and whole tablets remain on the top.

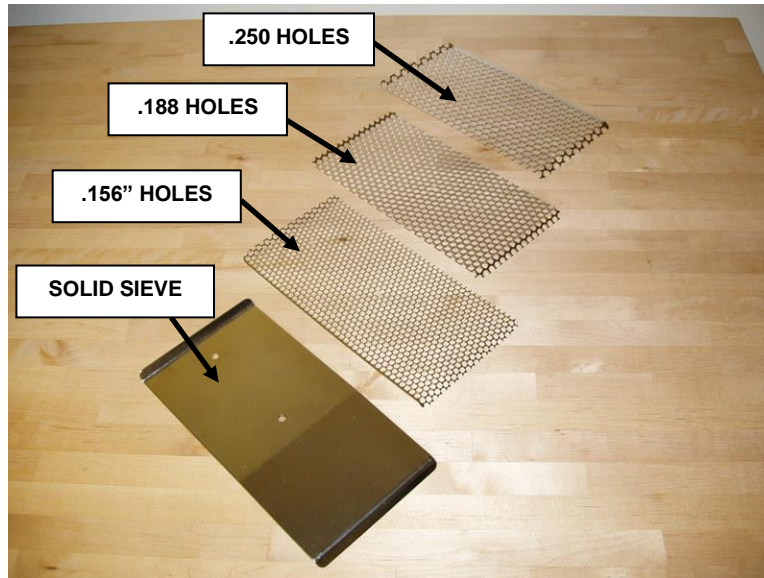

### 7.7.2 FUNNELS

Select the funnel size which best matches your container. Ideally, you want the funnel opening to be as large as possible, while still smaller than the opening of the container. Place one Funnel in each Funnel Holder and slide them both into the slot on the bottom of the Counting Head.



## 7.8 TESTING TO ESTABLISH PARAMETERS

For each product to be counted, you will have to establish the correct parameters for the best combination of speed and accuracy. We recommend the following method.

1. Hand-count a certain quantity of product (100 in this example) into a container. This will be your test batch.
2. Use the test batch to set the basic product guide adjustments to the machine for this product and note the settings.
  - a. Width of channel
  - b. Depth of guide plate
  - c. Height setting (mechanical or air guide)
  - d. Center position of head under chute
3. Using Check Count and starting at a very moderate speed, count the test batch several times.
4. If the counts are inaccurate, check the guide settings and continue counting.
5. Once the counts are accurate and repeatable, increase the speed slightly and continue counting.
6. Above a certain speed for each product, you will not be able to maintain accuracy. Go back to a lower speed and consider this the maximum speed for that product. Note the setting of the HIGH speed-control.
7. Set the LOW speed-control to approximately 2/3 of the value of the HIGH setting.
8. Set the TARGET COUNT to 50 and your SLOWDOWN COUNT to 49 (for now). Pour all the product onto the disc and use Manual mode to check the action of divider flag. Do this several times. The excess overrun quantity should be accurately counted. Adjust the FLAG DELAY if it is not accurate.
9. If the overrun is consistently more when directed to one-side than the other, the head may not be centered properly.
10. The amount of the overrun can help you to set the SLOWDOWN COUNT value: for example, if the overrun is consistently around 10 pieces, set the Slowdown Count to be at least 10 less than the Target Count.

## Section 8 – COUNTING & FILLING

**8.1 PREPARATION** - The machine should be cleaned before first use, and before running a new product.

- The product guides and counting head should be set for the product.
- The HIGH, LOW and FEED speeds should be set.
- The bottle shelf should be set for the preferred container.
- The correct funnels should be in place.
- Feeder sieve should be in place.
- The hopper should be filled, and the hopper door opened.
- The data for Target Count, Slowdown Count and Flag Delay should be set (if using AUTO or MANUAL modes).
- Count a known test batch to confirm accuracy.

**8.2 CHECK COUNT MODE** – count the contents of a pre-filled container.

- Place a container under each funnel.
- Press RESET.
- Press CHECK COUNT. The machine will start.
- Pour contents of pre-filled container onto glass disc.
- The contents will be counted, and the tally will be displayed until RESET is pressed again.
- Press CHECK COUNT again to stop and reset the counter to zero.

**8.3 MANUAL MODE**

- Place a container under each funnel.
- Press RESET.
- Press MANUAL. The machine will start.
- One container will be filled to the Target Count and the machine will stop.
- Any product that runs on after the stop will be counted and go in the alternate container.
- To continue, press MANUAL again.

**8.4 AUTOMATIC MODE**

- Place a container under each funnel.
- Press RESET.
- Press AUTO. The machine will start.
- The machine will fill the first container and then switch to filling the next container at the alternate funnel.
- As containers are filled, replace them with empty containers.
- Press AUTO again to stop.

## Section 9 –BREAKDOWN, CLEANING AND BUILDUP

### 9.1 BREAKDOWN OF REMOVE-TO-CLEAN CONTACT PARTS

1. Disconnect the cable connected to the **Auto-Feed Control** sensor by unscrewing it.
2. Remove the **Clear Rim Cover** – Loosen the front knob and rotate it up. Loosen the rear knobs, lift and slide cover out.
3. Remove the **Center Hub** – unscrew the knob and remove the hub.
4. Remove the **Product Guide Assembly** – unscrew the knob, slide the assembly to the right and lift.
5. Rotate the **Air Manifold Assembly** – pull the release pin and rotate the assembly up.
6. Remove the **Rim Band** – starting at the front, lift the band out of its groove, working your way around to the back.
7. Remove the **Glass Disc** – unscrew the hold-down ring nut, remove the clear plastic washer and lift off the glass.
8. Remove the **Counting Sensor and Sensor** – unlock the electrical cable by pulling the black ring down, then disconnect it by pulling the connector down. Remove the counting sensor by pulling down on the release clip at the bottom and rotating the sensor out. Loosen the knob on the left side of the counting window and remove the window and sensor as one piece. DO NOT let the window hang by the fiber optic cables. DO NOT separate the fiber optic cables from the sensor.
9. Remove the **Counting Head Clear Front Cover** – unscrew the three knobs and remove the cover.
10. Remove the **Funnel and Funnel Holders**– loosen the funnel knob and slide the funnel holder and funnel out.
11. Remove the **Left, Right and Center Head Blocks** – slide the blocks off the mounting posts.
12. Remove the **Funnel Block** – loosen the two knobs, letting the block drop until it is free.
13. Remove the **Feeder Pan Sieve Plate** – loosen two knobs and remove sieve plate.
14. Remove the **Hopper Door** – remove two knobs and lift door out of hopper.

### 9.1.1 STEP-BY-STEP BREAKDOWN

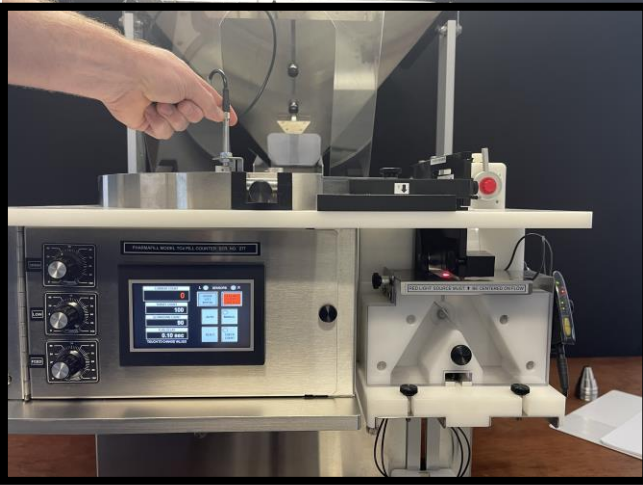

1. Disconnect the **Sensor Cable**.

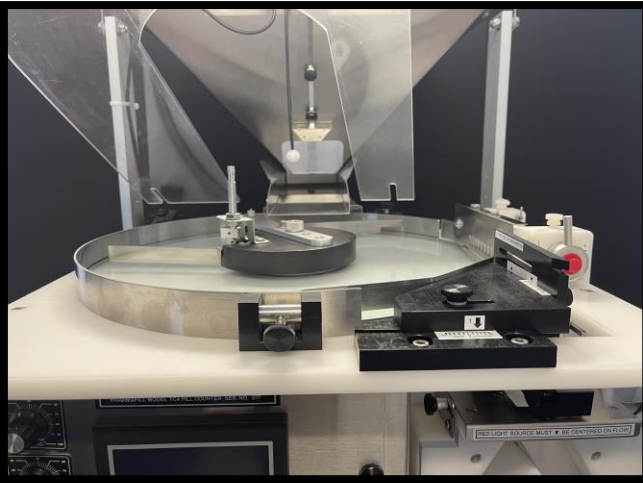

2. Remove the **Rim Dust Cover** by loosening the hold-down knob (front) and two mounting knobs (rear). The cover will slip out.

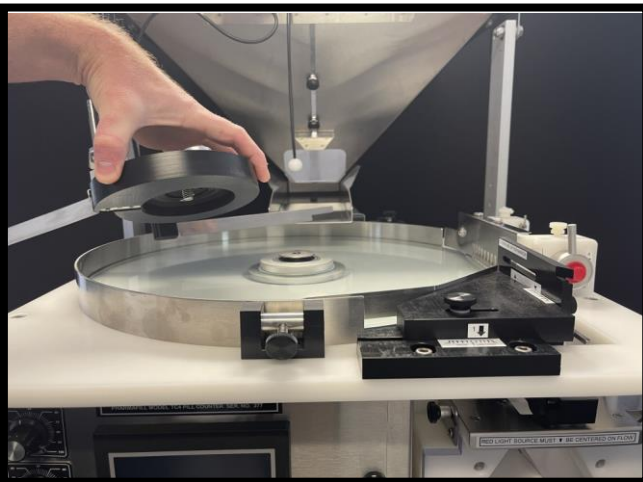

3. Remove the **Center Hub** (with **Deflector** attached) by unscrewing the **Center Knob**.

(First time – remove bubble pack under **Deflector**)



### 9.1.1 STEP-BY-STEP BREAKDOWN

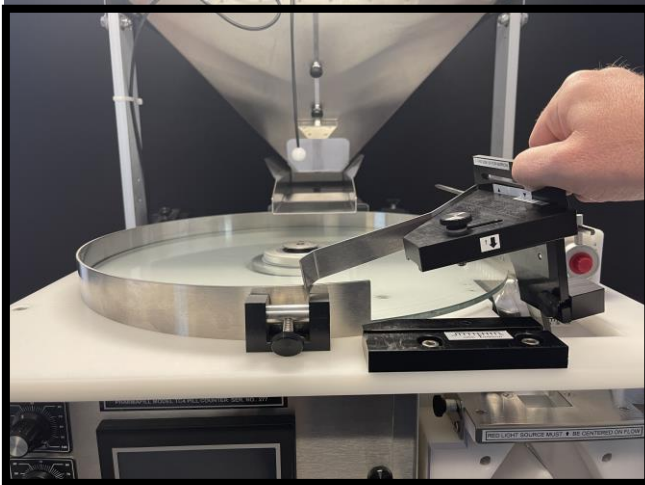

4. Remove the **Guide Block Assembly** by unscrewing the **Hold-Down Knob**.

(First time – remove bubble pack from under the **Flow Diverter**)

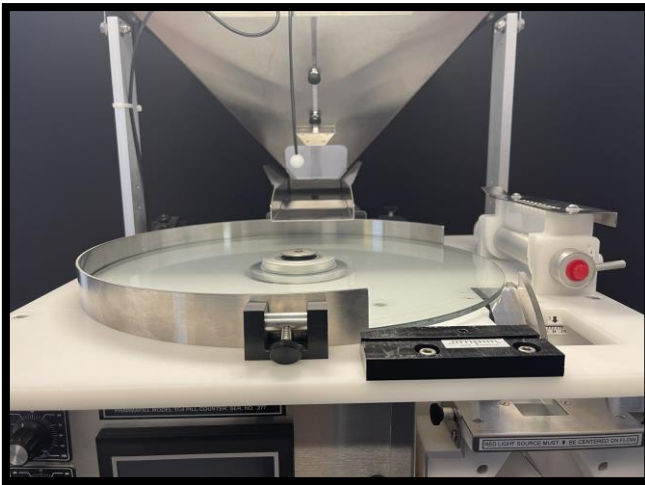

5. Move the **Flow Guide Assembly** out of the way by pulling on the **Release Pin** and swinging it up.

(First time – remove bubble pack under the **Flow Guide**)

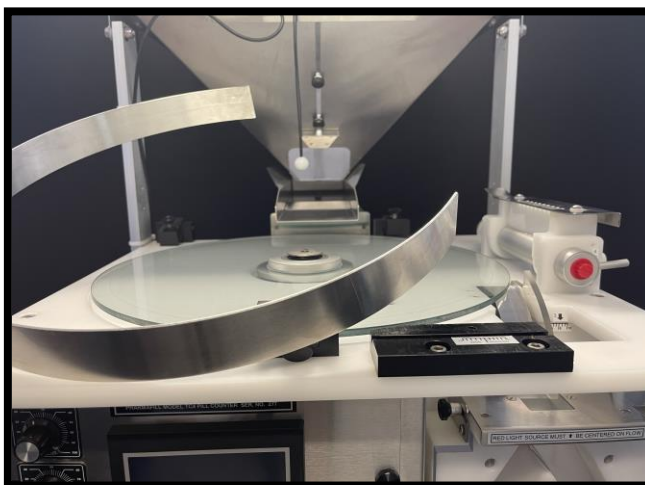

6. Remove the **Rim Band** by lifting it out of the groove in the top plate. Always start at one end and work your way along the length way to the other end. This works for both removal and installation.

### 9.1.1 STEP-BY-STEP BREAKDOWN

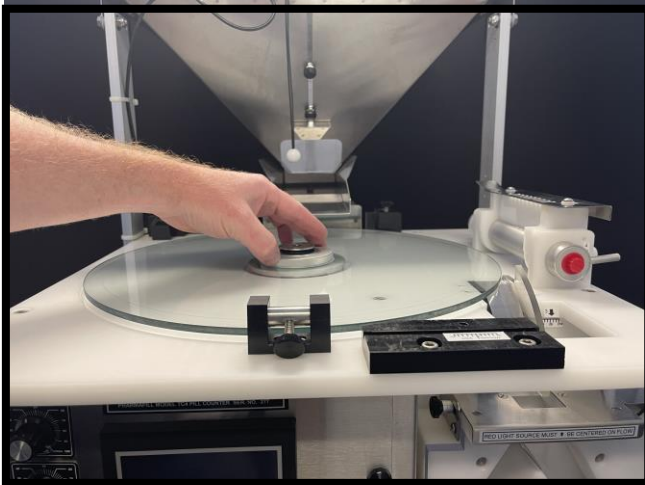

7. Unscrew the **Hold-Down Ring Nut**, then remove the and the **Hold-Down Ring Nut** and the **Thin Plastic Hold-Down Washer**.

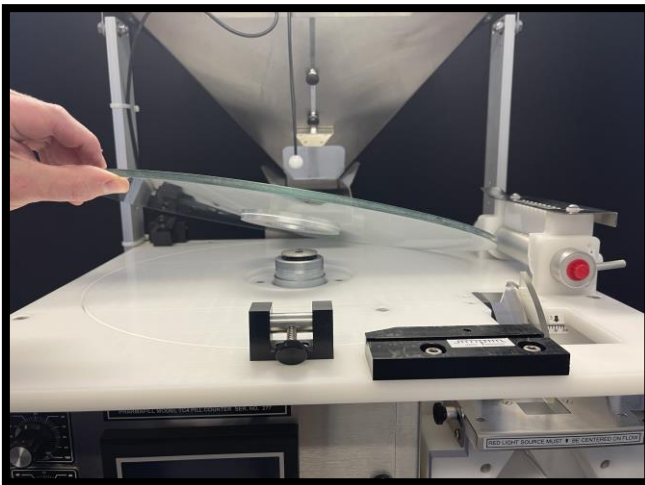

Lift the **Glass Disc** off the **Drive Hub**.

(First time – remove bubble pack from under the **Glass Disc**)

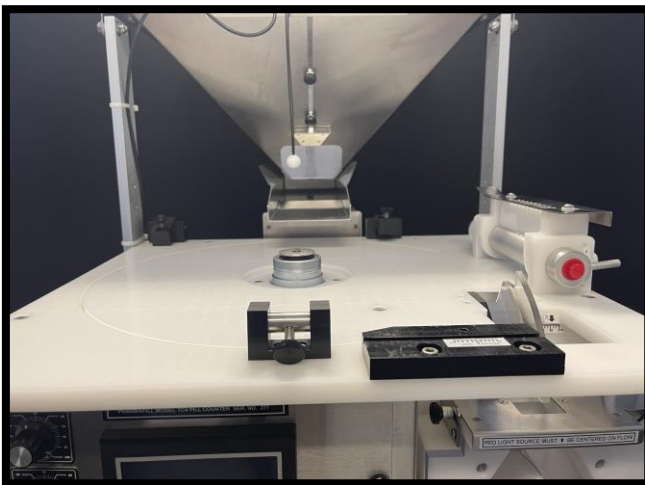

### 9.1.1 STEP-BY-STEP BREAKDOWN

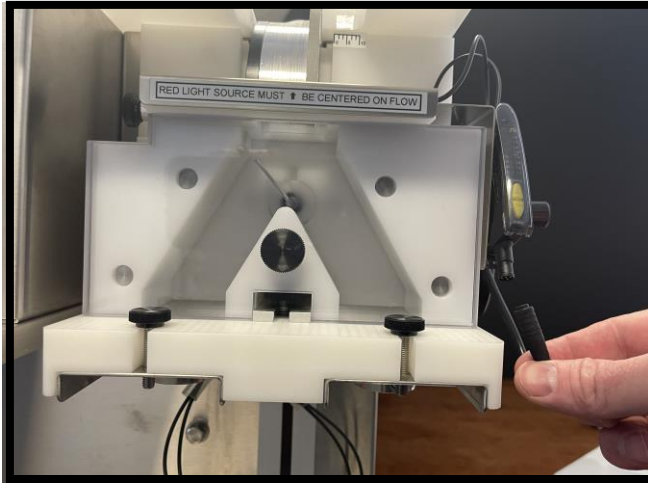

8. Remove the counting window and sensor – Disconnect the **Counting Sensor Electrical Cable**. Pull down on the connector to disconnect the cable.



Loosen the knob on the left side of the **Counting Window** and remove the **window** and **sensor** as one piece. **DO NOT** separate the **fiber optic cables** from the **sensor**.

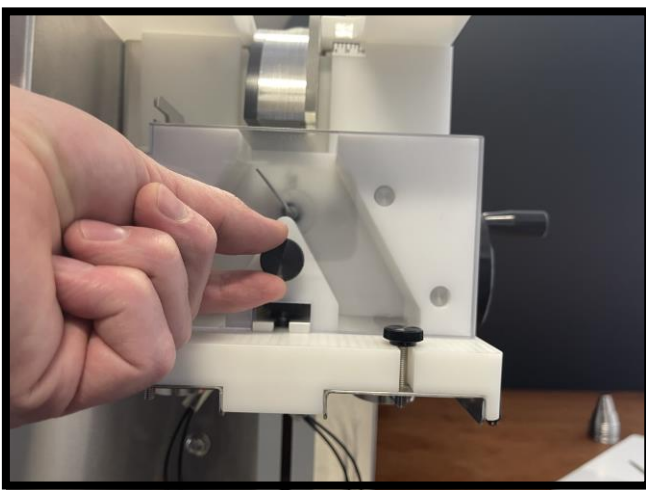

9. Remove the **Clear Front Cover** – unscrew the knob and remove the cover.

### 9.1.1 STEP-BY-STEP BREAKDOWN

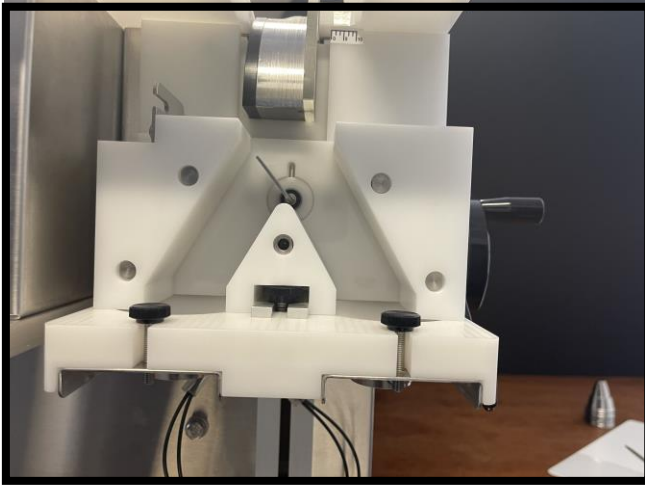

**Counting Head** with clear front cover removed.

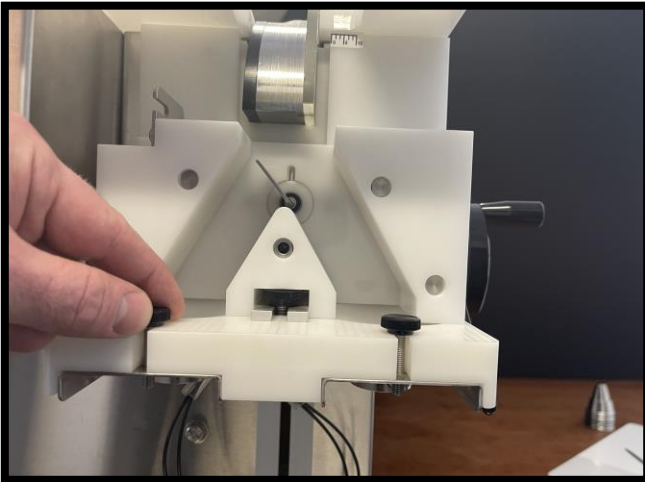

10. Remove the **Funnel Holders** and **Funnels** – loosen the funnel knob and slide the **funnel holders** and **funnels** out.

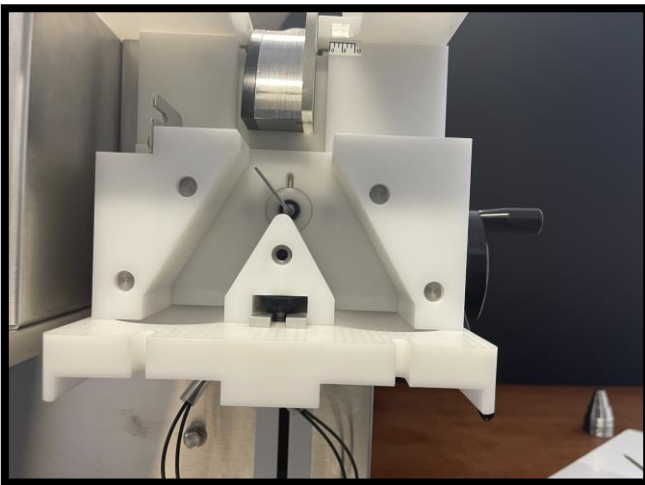

**Counting Head** with **funnel holders** and **funnels** removed.



### 9.1.1 STEP-BY-STEP BREAKDOWN

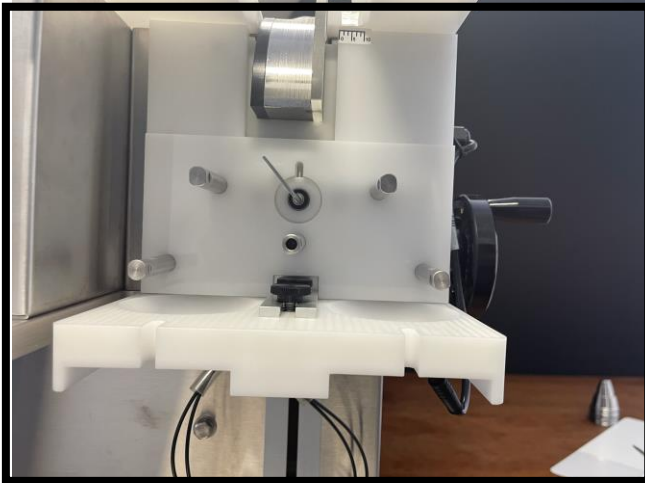

11. Remove the **Left, Right and Center Head Blocks** – slide the three blocks off the mounting posts.

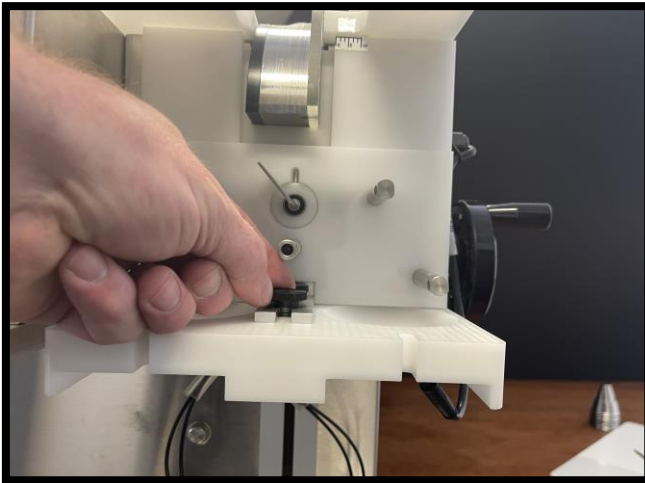

12. Remove the **Funnel Block**– loosen the two knobs, letting the block drop until it is free.

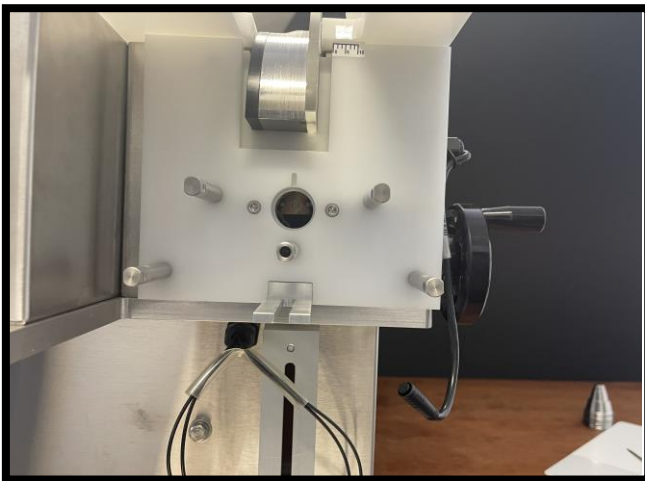

**Counting Head with Funnel Block removed.**



### 9.1.1 STEP-BY-STEP BREAKDOWN

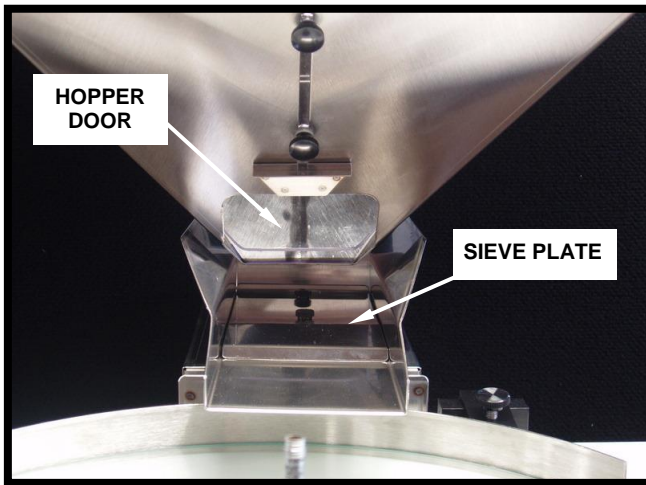

13. Remove the **Feeder Pan Sieve Plate** – loosen two knobs and remove **Sieve Plate**.

14. Remove the **Hopper Door** – remove two knobs and lift door out of **Hopper**.

**END 9.1.1**

## 9.2 BUILDUP OF REMOVE-TO-CLEAN CONTACT PARTS

Use the pictures in section 9.1.1 (Step-by-step Breakdown) in reverse order to help with this procedure.

1. Install the **hopper door** – put the door in place and secure with two knobs.
2. Install the **feeder sieve plate** – Install **sieve plate** and tighten two knobs.
3. Install the **funnel block** – raise the block as you tighten two knobs.
4. Install the **left, right and center head blocks** – slide the blocks onto the mounting posts.
5. Install the **funnel holder** and **funnel** – slide in the **funnel holder** and tighten the knob.
6. Install the **counting head clear front cover** – install the cover and tighten the knob.
7. Install the **counting window** and **sensor** – Install the window and sensor as one piece and tighten the knob on the left side of the counting window. Connect the electrical cable by aligning the prongs in the connectors and pushing up onto the sensor.
8. Install the **glass disc** – carefully place the **glass disc** onto the **hub**, aligning the groove in the **disc support ring** with the pin on the hub. Install the **cushioning washer** and screw down the **hold-down ring nut**.
9. Install the **rim band** – starting at the front, place the band in the groove, working your way around to the back. Make sure it is seated down all around.
10. Install the **product guide assembly** – position assembly and tighten the knob.
11. Install the **center hub** – Place the hub onto the center port, making sure to align the pin in the hub with the hole in the post. Tighten the knob.
12. Rotate the **air manifold assembly** into place– rotate the assembly down and press the release pin to assure that it has engaged the locating hole.
13. Install the **clear rim cover** – Slide the cover onto the rear knobs and tighten. Close the cover and tighten the front hold-down knob.
14. Connect the electrical cable to the **Auto-Feed Control sensor** by aligning the connector and screwing it on.

### **9.3 CLEAN-IN-PLACE CONTACT PARTS**

The following must be cleaned in place unless further disassembly is done using tools. Contact the factory if you need assistance.

1. Hopper – wipe down inside surfaces.
2. Feeder pan - wipe down inside surfaces.
3. Inner chute – wipe down all visible inside surfaces
4. Divider Flag
5. Counting head Back Plate

### **9.4 NON-CONTACT AREAS**

1. Feeder pan dust chute and dust box – clean out dust box by removing four screws from the rear cover and wiping or blowing with compressed air (wear eye protection, please).
2. All other surfaces – follow guidelines in the next section.

### **9.5 CLEANING RECOMMENDATIONS**

#### Washdown

This machine is not waterproof and is not intended for full wash down. If full washdown is performed on the equipment near the machine, it must be completely protected by a waterproof cover or by other means. Washdown will void the warranty.

#### Cleaning solutions

Glass and stainless steel are resistant to most cleaning solutions. Other contact materials such as aluminum and nonmetallics (plastics, or rubber) are generally less corrosion-resistant and care should be exercised in their cleaning. Aluminum is readily attacked by acids as well as highly alkaline cleaners, which can render the surface non-cleanable. Plastics are subject to stress cracking and clouding from prolonged exposure to corrosive cleaning agents. Use a USDA approved sanitizing solution that is safe for all materials listed below, in a spray bottle, by lightly wiping down all contact surfaces. In the absence of such a cleaner, recommendations follow.

#### Recommendations

Glass (tempered): This material is resistant to damage from most cleaners. Routine cleaning can be done with soap and water, alcohol or acetone.

**Stainless steel:** This material is resistant to damage from most cleaners. Routine cleaning can be done with soap and water, alcohol or acetone.

**Anodized aluminum:** Any highly acidic or alkaline cleaner will etch the aluminum over time and damage it. Soap and water, or alcohol is acceptable.

**Clear plastic:** The clear plastic material is polycarbonate (known as Lexan). Cleaning with alcohol or acetone will damage it and should never be used. Ammonia or any strong cleaner will make it cloudy over time. It may be safely cleaned with soap and water.

**Other plastic:** All other manufactured plastic parts are made from acetal (known as Delrin). It is resistant to damage from most cleaners. Routine cleaning can be done with soap and water, or alcohol. White acetal will yellow over time due to exposure to ultraviolet light in the environment. This is normal and cannot be removed by cleaning. Some cleaners may accelerate this process.

## **Section 10 - TECHNICAL INFORMATION**

### **10.1 PRINCIPLE OF OPERATION**

The Pharmafill Model TC4 is an electronic pill counter/filler. It can count objects other than pills, but the primary purpose is to count pills (tablets, capsules, caplets, most solid oral dose products). The pills are counted using photoelectric sensing. Once counted the pills are directed into pre-staged bottles. It may be used as a check counter, as a manual bottle-filling machine (one bottle at a time), or as a semi-automatic filler (one bottle after another, continuously).

A supply of product to be counted is distributed to a rotating glass disc. A single-file stream of pills is guided off the edge of the glass and down a curved chute, where the pills space out as they fall. As the pills exit the chute, they pass through the counting window, containing a light source and light receiver that are connected to a counting sensor. As each pill briefly blocks the light source, the counting sensor detects the change in light level and sends a count signal to the PLC computer, which maintains the tally.

The PLC compares the tally against two pre-set values: slowdown count and target count. The slowdown count must be less than the target count. When the slowdown count is met, the rotation speed of the glass disc slows down. This aids in the action of the divider flag (see below). When the target count is matched, the glass disc resumes full speed.

After passing through the counting window, the pills strike the divider flag, which directs the stream of pills into one of two exit funnels, one on the left and one on the right. When the tally matches the target count, the divider flag switches sides, starting a new count at zero on the alternate side. The action of the divider flag must be timed perfectly to split the stream of pills precisely after last pill of the target count and before the first pill of the next count.

When used as a manual filler (MANUAL mode), the machine will stop each time the target count is met. The divider flag will flip, and any excess pills will be tallied but the stream will stop.

When used as a semi-automatic filler (AUTO mode), the stream will be continuous to the right or left funnels alternately. The operator must take away filled bottles and supply empty ones when required.

When used for count verification only (CHECK COUNT Mode), the machine will only deliver and count the product. It will not automatically reset to zero or flip the divider flag; the user must press RESET to do this. The Target and Slowdown counts are not used.



## 10.2 CYCLE OF OPERATION

When power is on, the counting function is active and anything that passes through the counting window will be tallied.

### Automatic Cycle

1. If AUTO button is pressed (latch)
2. Glass disc rotates at HIGH speed (set by potentiometer)  
Feeder starts (if equipped)  
If tally  $\geq$  SLOWDOWN COUNT,
3. Glass disc rotates at LOW speed (set by potentiometer)  
If tally=TARGET COUNT
4. Divider flag flips  
Count tally reset to zero  
Glass disc resumes HIGH speed
5. If AUTO button is pressed again (unlatch)  
Glass disc stops  
Feeder stops (if equipped)

### Manual Cycle

1. If MANUAL button is pressed (latch)
2. Glass disc rotates at HIGH speed (set by potentiometer)  
Feeder starts (if equipped)  
If tally  $\geq$  SLOWDOWN COUNT,
3. Glass disc rotates at LOW speed (set by potentiometer)  
If tally=TARGET COUNT
4. Exits MANUAL mode (unlatch)  
Divider flag flips  
Count tally reset to zero  
Glass disc stops  
Feeder stops  
Excess pills are counted, and tally is maintained

### Check Count Cycle

1. If CHECK COUNT button is pressed (latch)
2. Glass disc rotates at HIGH speed (set by potentiometer)  
Feeder starts (if equipped)
5. If CHECK COUNT button is pressed again (unlatch)  
Glass disc stops  
Feeder stops (if equipped)  
Count tally reset to zero

## 10.3 TROUBLESHOOTING

- a. No power overall or to some components.
  - Check power cord is plugged in and in good condition.
  - Check Main Switch is on (at Power Entry Module).
  - Check STOP is released.
  - Check main fuse F1 in Power Entry Module.
  - Check all component fuses inside behind right side access panel (LED "on" indicates blown fuse).
- b. Front control panel does not light up.
  - Check component fuse F6 (OP1) inside behind right side-access panel.
  - Check 24 VDC power connections at panel and at power supply.
  - Check that PS1 24 VDC power supply is working.
- c. Have power but no response to action keys on front control panel.
  - Check component fuse F2 (PLC) inside behind right side-access panel (LED "on" indicates blown fuse).
  - Check PLC is in run mode and terminal position.
  - Check PLC is connected to front control panel via data cable.
- d. Disc does not rotate in any mode.
  - Check component fuse F4 (SC1) inside behind right side-access panel (LED "on" indicates blown fuse).
  - Check speed control knobs for HIGH and LOW are set above 10%.
  - Check relays REL1 & REL2 next to PLC, inside front access door.
  - Check speed control SC1 behind right side access panel.
- e. Disc stops before target count is reached but starts upon reset.
  - Check speed control knob for LOW is set above 10%.
- f. Feeder does not operate
  - Check the electrical connector between the back of the machine and the feeder.
  - Check component fuse F5 (SC2) inside behind right side-access panel (LED "on" indicates blown fuse).
  - Check speed control knob for FEED is set above 10%.
  - Check relay REL3 next to PLC, inside front access door.
  - Check speed control SC2.
- g. Feeder stops too often (if equipped with Auto Feed Sensor)
  - Check the mechanical adjustments of the sensor target and product deflector.
  - Check the Auto-feed sensor for electrical function. Feeder should stop when yellow light sensor turns on.
  - Check that the red input light X1 on the PLC turns on whenever the yellow light on the sensor turns on.
  - Check the electrical connector between the back of the machine and the feeder.

- h. Auxiliary outlet has no power.
  - ❑ Check component fuse F3 (outlet) inside behind right side-access panel (LED “on” indicates blown fuse).
  
- i. Divider Flag does not flip (does not switch sides alternately)
  - ❑ Power down and check that the flag moves freely back and forth.
  - ❑ Check the electrical connections to the left and right actuator solenoids.
  - ❑ Check that the red output lights Y4 and Y5 on the PLC turn on alternately for left and right.
  
- j. Count is not accurate – too many in container (sensor missing pills)
  - ❑ Check that the counting head is centered on the exit chute.
  - ❑ Check that the bar graph indicator lights on the counting sensor are dropping and rising as objects pass through the sensor.
  - ❑ Check that the product flow is consistently single file, one level high (no doubles or piggy backs)
  - ❑ Contact Deitz Company for more detailed troubleshooting help.
  
- k. Count is not accurate – too few in container
  - ❑ In the case of clear or translucent product, check the adjustment the one-shot delay.
  - ❑ Check that small chips are not being counted as whole
  - ❑ In the case of long or irregularly shaped product, make sure that the product is not tumbling through the counting window and occasionally being counting twice.
  - ❑ Contact Deitz Company for more detailed troubleshooting help.
  
- l. Count is not accurate – random
  - ❑ Contact Deitz Company for more detailed troubleshooting help.

**10.4 Index of Technical Notes/Drawings (document section begins after this page)**

<u>Doc. No.</u>	<u>Title</u>	<u>No. of Pages</u>
TC4-AD1154-DIM	Dimensions and specification	2
TC4-AD1154-CCD	Contact Compliance Document	1
TC4-AD1154_PM-Safety	Preventative Maintenance & Safety Device	1
TN0101A	“No Bottle” Sensors	2
SC 1011	TC4 Electrical Schematic	10

Addendums or additional technical data

_____	_____	__
_____	_____	__
_____	_____	__
_____	_____	__
_____	_____	__
_____	_____	__
_____	_____	__
_____	_____	__
_____	_____	__



JOHN DEITZ  
President

Deitz Company Inc.  
1750 Route 34 PO Box 1108  
Wall, NJ USA 07719

Tel 732-681-0200  
Fax 732-681-8468  
Email sjd2@deitzco.com

---

**CONTACT COMPLIANCE DATA**

 Model TC4 Electronic Counter Type AD1154
 

---

**FOOD COMPLIANCE STATEMENTS**
**MATERIALS IN DIRECT CONTACT WITH PRODUCT**

Deitz Company Inc hereby certifies that the list below contains all the parts of the above-cited machine that come in direct contact with the product, and that those parts are manufactured using raw materials and surface treatments which conform to the requirements of such parts as established by the Food and Drug Administration of the United States. Certificates of compliance for raw materials and treatments are maintained according to our internal Quality Control System or to that of our material and treatment suppliers.

---

**CONTACT PARTS, MATERIALS AND TREATMENTS**

PART NUMBER	DESCRIPTION	MATERIAL	CERTIFICATION
FA1021	Hopper	SS304	ASTM Standard
FM3492	Hopper Door	Polycarbonate	FDA 21 CFR 177.1580
FM3836-0, -.12, -.19, -.25	Sieve Plate, Solid, .12, .19, .25	SS304	ASTM Standard
P3508	Sieve Plate Knob	Polyethylene	FDA 21 CFR 177.1600
FM3474	Feed Tray	SS304	ASTM Standard
P2502	Disc	Float Glass	ASTM Standard
FM3540	Rim	SS304	ASTM Standard
FM3462	Center Hub	Acetal	FDA 21 CFR 177.2480
FM3481-3 LONG	Deflector Arm 8"	SS304	ASTM Standard
FM3481-3 SHORT	Deflector Arm 5"	SS304	ASTM Standard
FM3548-1 (see AD1134-2)	Flow Guide	SS304	ASTM Standard
FM3528	Product Guide	SS304	ASTM Standard
FM3489	Adj. Guide Block Shield	SS304	ASTM Standard
FM3433 (see FA1018)	Fixed Chute Center	SS303	ASTM Standard
FM3432 (see FA1018)	Fixed Chute Left Side	Acetal	FDA 21 CFR 177.2480
FM3431 (see FA1018)	Fixed Chute Right Side	Polycarbonate	FDA 21 CFR 177.1580
FM3442	Adj. Product Guide Plate	Acetal	FDA 21 CFR 177.2480
FM3456	Adj. Chute Side Plate	Acetal	FDA 21 CFR 177.2480
FM3458	Chute Cover, Clear	Polycarbonate	FDA 21 CFR 177.1580
FM3494	Counting Window Clear Cover	Polycarbonate	FDA 21 CFR 177.1580
FMA1386	Diverter Flag Ass'y	SS304	ASTM Standard
FM3541	Head Back Plate	Acetal	FDA 21 CFR 177.2480
FM3543	Head Side Block L&R	Acetal	FDA 21 CFR 177.2480
FM3542	Head Center Block	Acetal	FDA 21 CFR 177.2480
FM3544	Head Front Cover, Clear	Polycarbonate	FDA 21 CFR 177.1580
FM3545	Head Funnel Block	Acetal	FDA 21 CFR 177.2480
FM1393 thru FM1396	Funnel	SS304	ASTM Standard

---

**Legal disclaimer: Deitz Company believes the above information to be truthful, based on information provided to us from our suppliers. However, Deitz Company cannot guarantee the accuracy of the reporting, testing or procedures of our suppliers and assumes no liability or obligation as to the same. Deitz Company also assumes no liability as to the suitability of the above materials to the application for which the customer intends to use the machine. It is the customer's responsibility to assure that the above materials meet the customer's requirements.**

---





---

JOHN DEITZ  
President

Deitz Company Inc.  
1750 Route 34 PO Box 1108  
Wall, NJ USA 07719

Tel 732-681-0200  
Fax 732-681-8468  
Email [sjd2@deitzco.com](mailto:sjd2@deitzco.com)

---

## Pharmafill TC4 Electronic Counter

### Preventive maintenance

There is little preventative maintenance required on the machine other than routine cleaning and inspection. There are no lubrication points. All bearing are sealed and/or permanently lubricated.

Every six months –

1. Remove the right side access panel.
2. Visually inspect the condition and tightness of the disc drive belt. If the belt appears excessively loose, you may adjust it by loosening the motor assembly mounting screws and moving the motor assembly back. Adjust it so there is no slack. Since it is a toothed belt, there is no need for additional tension. If the belt is appears worn, replace it.

P0418 Belt,Gear - 150XL037

3. Visually inspect the condition of the flag actuator linkage. If the hole in the linkage appears excessively worn, replace it. The shape of the hole should be a perfect obround (oval). Rounding of the hole indicates wear.

SD1438 Actuator Link

### Safety device

There are no hazardous aspects to the routine operation of the machine. There are no dangerous moving parts or sharp edges. Therefore there are no guards or interlocks to prevent operation.

For quick, convenient stoppage of the machine operation, there is a twist-to-unlock emergency stop button. The machine will not restart when the stop switch is released. The start button must be pressed to start.

For safe internal inspection and service, there is a main power disconnect switch.

There are separate internal fuses for all electrical loads.

1. Bottle Locator with fiber optic cables.

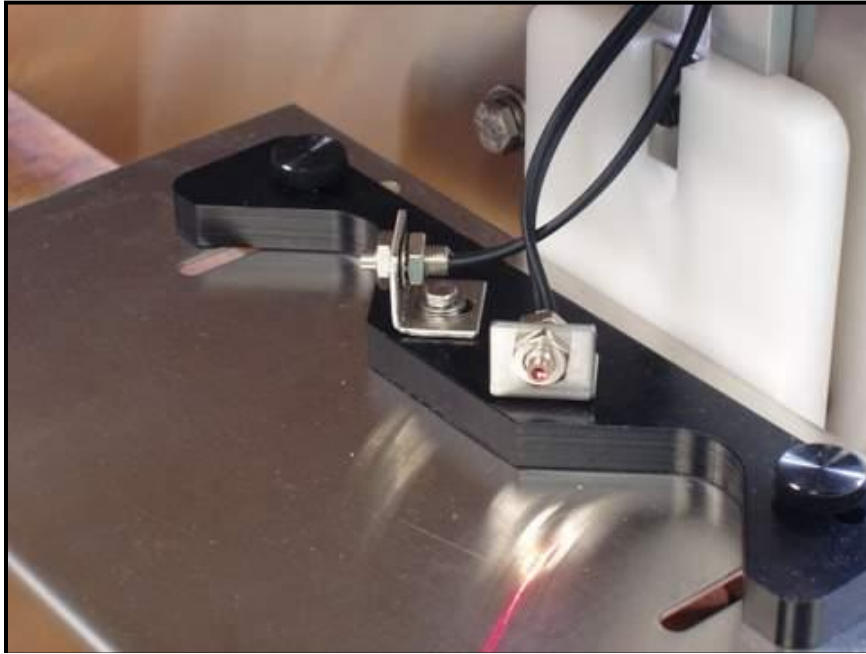

2. Fiber optic sensors (far left end of terminal board). The right sensor is “SN4 Right Bottle”. The left sensor is “SN5 Left Bottle”. Yellow knob adjusts sensitivity (gain): turn clockwise to increase.



### 3. Sensor Test











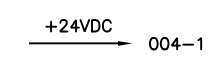

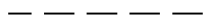
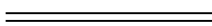
- a. Place an object in front of the left bottle sensor. On the PLC, the red light marked X2 should turn OFF.
- b. Place an object in front of the right bottle sensor. On the PLC, the red light marked X3 should turn OFF.

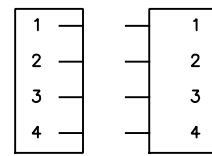
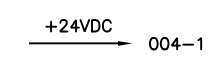
### 4. Function Test

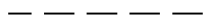
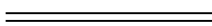
- a. Using the front panel, set the Target Count to 10, set the Slowdown Count to 5. Press RESET. Observe which side will be filling first (LEFT or RIGHT)
- b. Set the disc speed to HIGH=50 and LOW=25.
- c. Remove the clear chute cover and open the guides wide, so that you can use your finger to make count signals.
- d. Place bottles in the left and right filling positions. Observe that red lights X2 and X3 turn on.
- e. Press AUTO. The disc should turn at the higher speed.
- f. Remove the bottle from the filling side. The disc should stop, indicator light should flash.
- g. Replace the bottle. The disc should start turning again.
- h. Remove the bottle from the non-filling side. The disc should not stop.
- i. Use your finger to raise the count to the Slowdown count of 5. The disc should stop, indicator light should flash.
- j. Replace the bottle. The disc should start turning again at the slower speed.
- k. Use your finger to raise the count to the target count of 10. The diverter flag should switch sides.
- l. Repeat the test from step “f.”, filling to the opposite side.

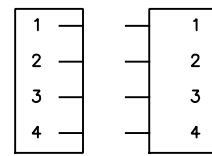
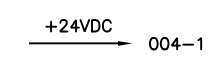
### 5. Functional Description

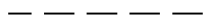
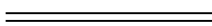
- a. When using Slowdown Count (Slowdown Count is greater than zero and less than Target Count) and Current Count = Slowdown Count and NEXT bottle is missing, stop.
- b. When NOT using Slowdown Count (Slowdown Count equals zero, or is equal to or greater than Target Count) and Current Count = Target Count and FILLING bottle is missing, reset and stop
- c. Flash appropriate indicator light to show which side is causing error.

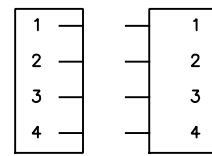
1	2	3	4	5	6	7	8	9	10												
<u>REVISIONS</u> (A) - 2017-06-21 - UPDATED DRAWING TO DOCUMENT DETAILS ADDED SINCE 2007. ADDED BATCH COUNTER OUTPUT AT Y0 (SEE PGS. 2, 7 & 10). ADDED OPTIONAL LEFT & RIGHT BOTTLE SENSOR INPUTS AT X2 & X3 (SEE PGS. 6 & 10).  (B) - 2018-11-06 - "HMI TOUCH SCREEN" (C-MORE) WAS "OP1 OPERATOR INTERFACE" (OPTIMATE)				<u>CONTENTS</u> 1. NOTES AND REVISIONS 2. COMPONENT IDENTIFICATION 3. 110VAC POWER ENTRY 4. 110VAC LOADS 5. 24VDC DISTRIBUTION 6. INPUTS: X0-X1 7. OUTPUTS: Y1-Y5 8. RELAY AND POTS DETAILS 9. SPEED CONTROL DETAILS 10. CONTROLLER (PLC)			<table border="0"> <tr> <td style="text-align: center;"><u>SYMBOL</u></td> <td style="text-align: center;"><u>KEY</u></td> </tr> <tr> <td style="text-align: center;">  </td> <td style="text-align: center;">  </td> </tr> <tr> <td style="text-align: center;">  </td> <td style="text-align: center;">JUMPED TERMINALS</td> </tr> <tr> <td style="text-align: center;">  </td> <td style="text-align: center;">INTERFACE CABLE</td> </tr> <tr> <td style="text-align: center;">  </td> <td style="text-align: center;">MULTI-PIN CONNECTOR (MOLDED)</td> </tr> <tr> <td style="text-align: center;">  </td> <td style="text-align: center;">MULTI-PIN CONNECTOR (SOLDERED)</td> </tr> </table>			<u>SYMBOL</u>	<u>KEY</u>				JUMPED TERMINALS		INTERFACE CABLE		MULTI-PIN CONNECTOR (MOLDED)		MULTI-PIN CONNECTOR (SOLDERED)
<u>SYMBOL</u>	<u>KEY</u>																				
																					
	JUMPED TERMINALS																				
	INTERFACE CABLE																				
	MULTI-PIN CONNECTOR (MOLDED)																				
	MULTI-PIN CONNECTOR (SOLDERED)																				

NUMBER  
 SC1011  
  
 PAGE  
 001

-	-	-	--/--/--
NOTE	REV	DESCRIPTION	DATE

DEITZ COMPANY, INC ROUTE 34, WALL, N.J. TECHNICAL DRAWING - PRODUCT INFO		SECTION NOTES AND REVISIONS TITLE MODEL TC4 PILL COUNTER WIRING SCHEMATIC SERIAL NO. 001 AND UP	BY SJD2 DATE: 2007-11-09 SHEET 001 OF 010 NUMBER SC1011 REVISION B
--	--	--	--

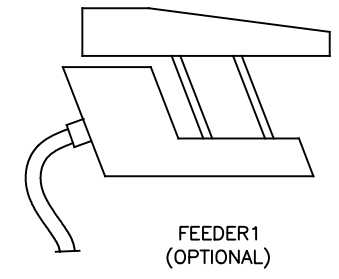
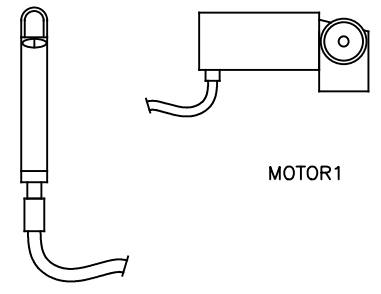
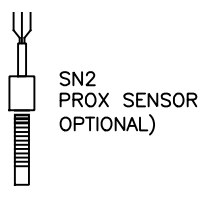
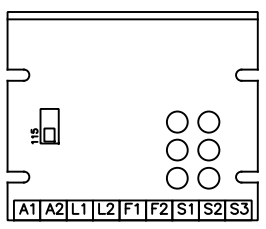
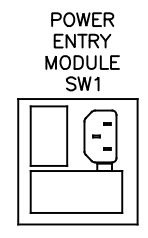
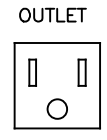
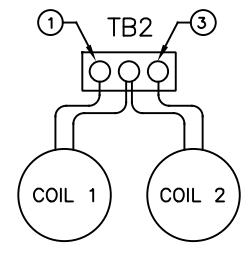
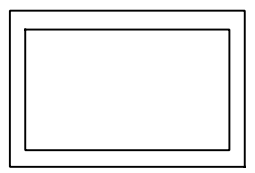
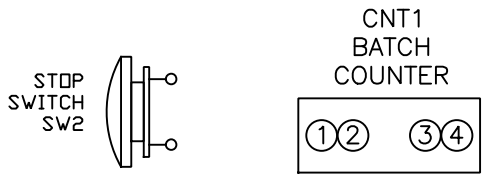
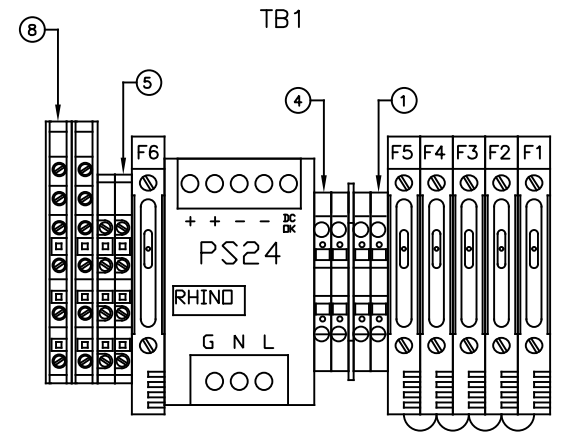
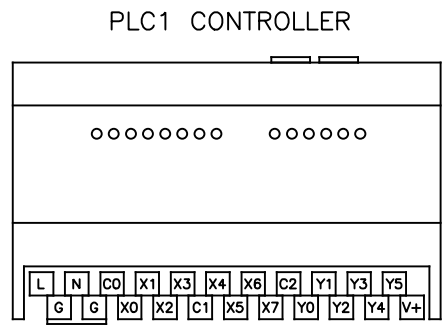
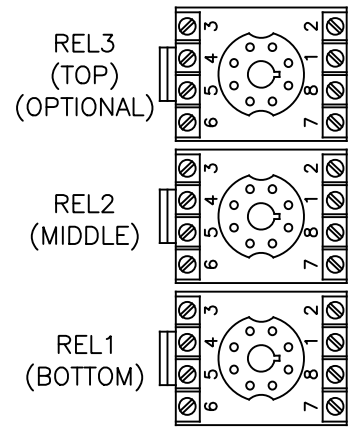
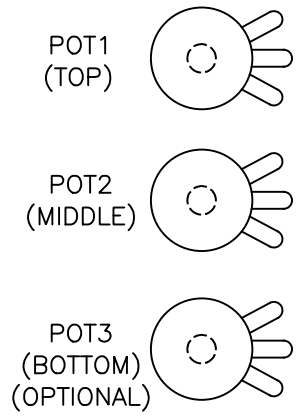

SN1 COUNTING SENSOR  
SN3, SN4 BOTTLE SENSORS

SC1 SPEED CONTROL - MOTOR  
SC2 SPEED CONTROL - FEEDER (OPTIONAL)

NUMBER  
SC1011  
  
 PAGE  
002

NOTE	REV	DESCRIPTION	DATE
-	-	-	---/---/---

DEITZ COMPANY, INC  
 ROUTE 34, WALL, N.J.  
 TECHNICAL DRAWING - PRODUCT INFO

SECTION	COMPONENT IDENTIFICATION	BY	DATE:
TITLE	MODEL TC4 PILL COUNTER WIRING SCHEMATIC SERIAL NO. 001 AND UP	SJD2	2007-11-09
		SHEET	002
		NUMBER	SC1011
		REVISION	B

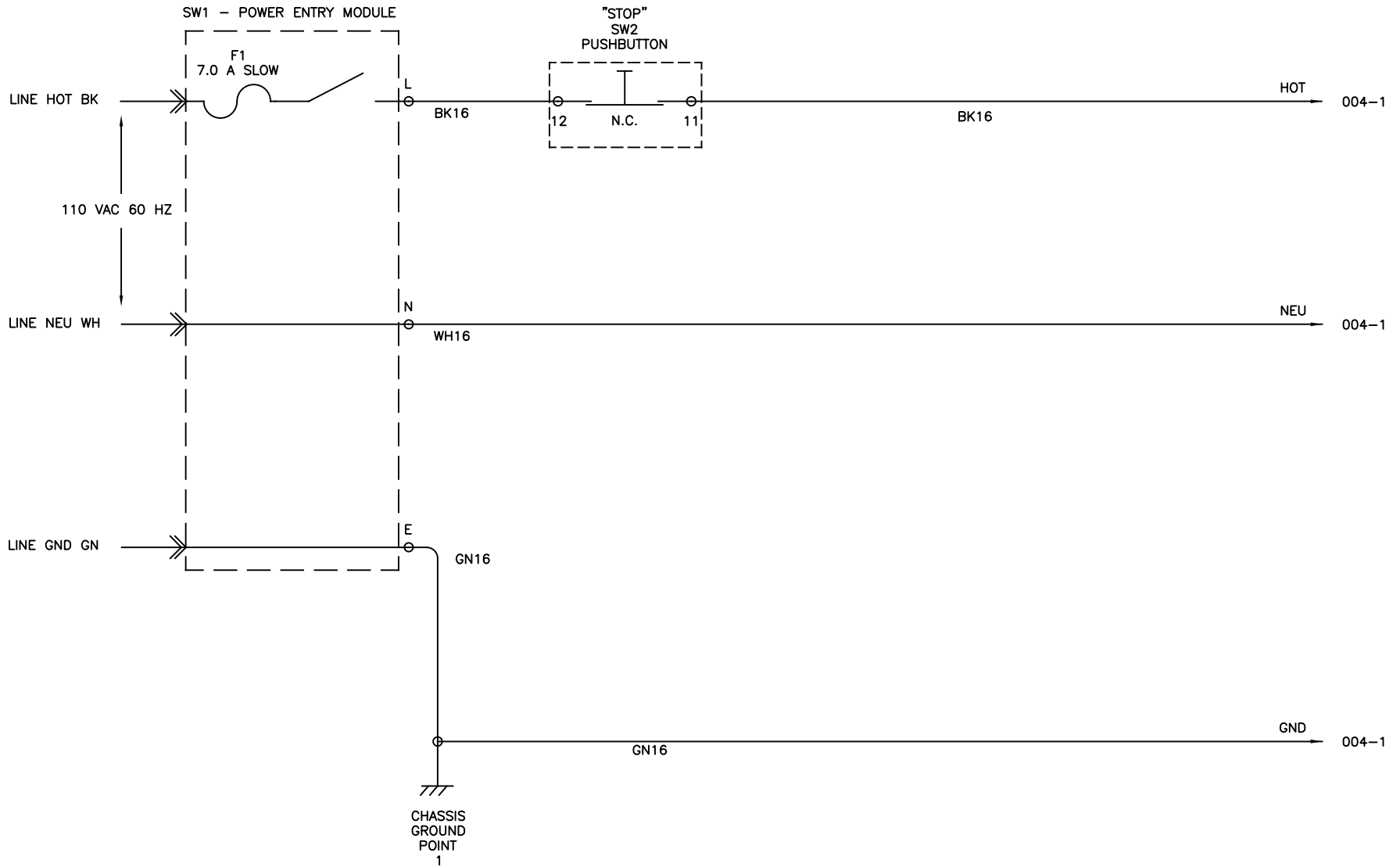

NUMBER  
 SC1011  
 PAGE  
 003

-	-	-	--/--/--
NOTE	REV	DESCRIPTION	DATE

CHASSIS  
GROUND  
POINT  
1

DEITZ COMPANY, INC  
 ROUTE 34, WALL, N.J.

TECHNICAL DRAWING - PRODUCT INFO

SECTION	110VAC POWER ENTRY	BY	SJD2	DATE:	2007-11-09
TITLE	MODEL TC4 PILL COUNTER WIRING SCHEMATIC SERIAL NO. 001 AND UP	SHEET	003		
NUMBER	SC1011	REVISION	A		



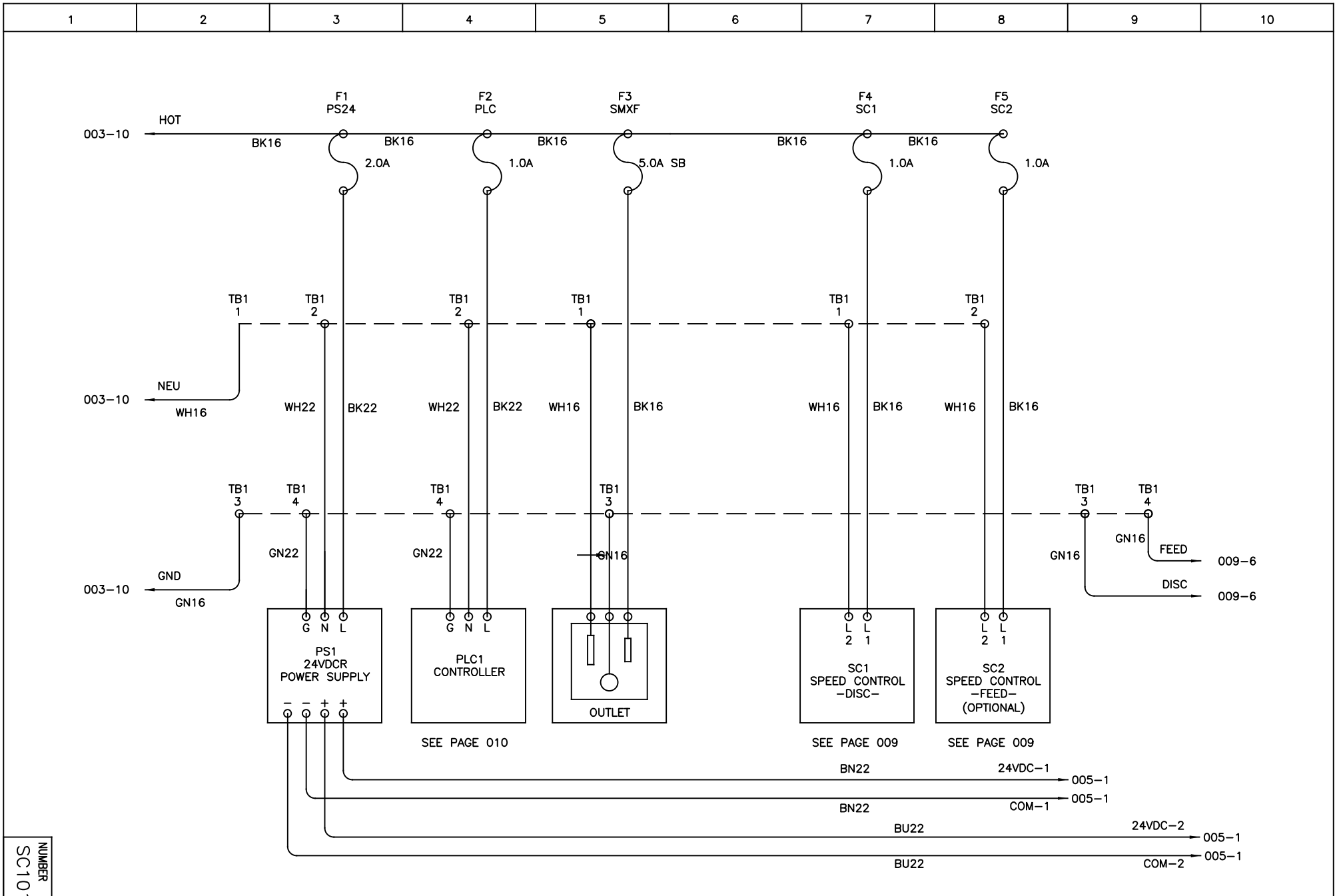

NUMBER  
 SC1011  
 PAGE  
 004

NOTE	REV	DESCRIPTION	DATE
-	-	-	---/---/---

DEITZ COMPANY, INC  
 ROUTE 34, WALL, N.J.  
 TECHNICAL DRAWING - PRODUCT INFO

SECTION	110VAC LOADS		BY	SJD2	DATE:	2007-11-09
TITLE	MODEL TC4 PILL COUNTER WIRING SCHEMATIC SERIAL NO. 001 AND UP		SHEET	004		
			NUMBER	SC1011		
			REVISION	A		

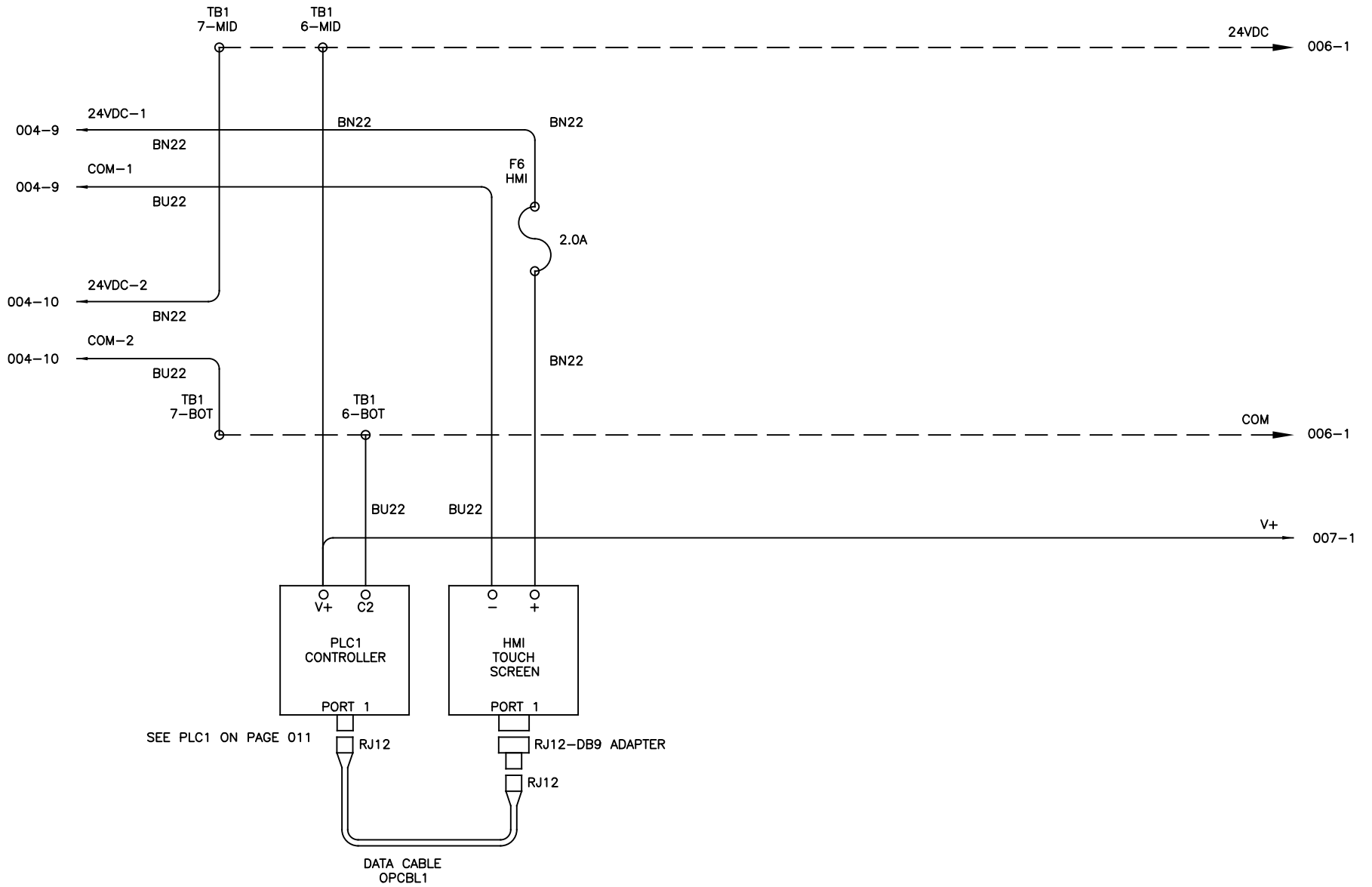

NUMBER  
 SC1011  
 PAGE  
 005

-	-	-	--/--/--
NOTE	REV	DESCRIPTION	DATE

DEITZ COMPANY, INC  
 ROUTE 34, WALL, N.J.  
 TECHNICAL DRAWING - PRODUCT INFO

SECTION	24VDC DISTRIBUTION	BY	SJD2	DATE:	2007-11-09	
TITLE	MODEL TC4 PILL COUNTER WIRING SCHEMATIC SERIAL NO. 001 AND UP	SHEET	005			
		NUMBER	SC1011	REVISION	B	

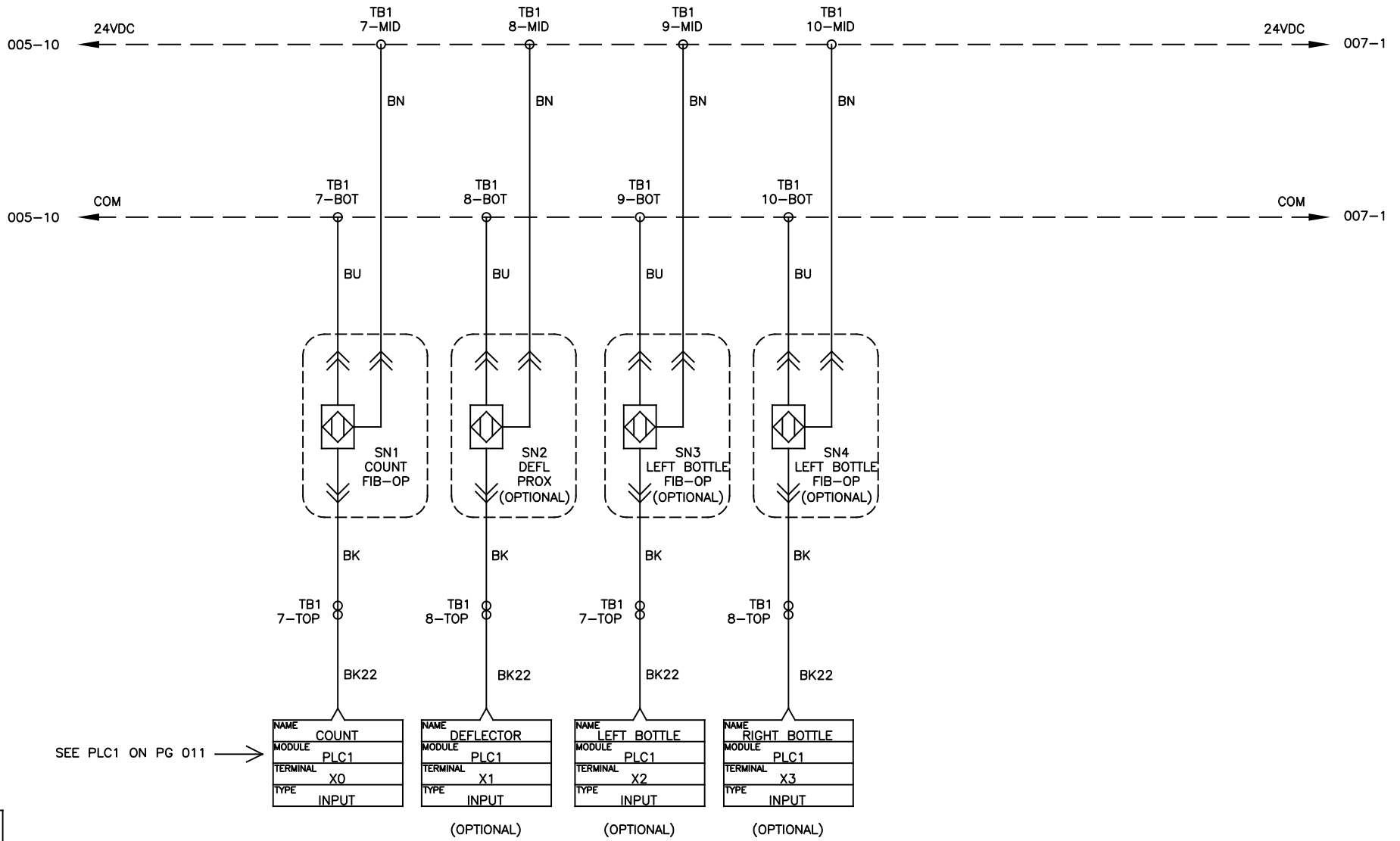

NUMBER  
SC1011  
  
 PAGE  
006

-	-	-	--/--/--
NOTE	REV	DESCRIPTION	DATE

DEITZ COMPANY, INC  
 ROUTE 34, WALL, N.J.  
 TECHNICAL DRAWING - PRODUCT INFO

SECTION	INPUTS: X0 - X1	BY	SJD2	DATE:	2007-11-09
TITLE	MODEL TC4 PILL COUNTER WIRING SCHEMATIC SERIAL NO. 001 AND UP		SHEET	006	
	NUMBER	SC1011		REVISION	A

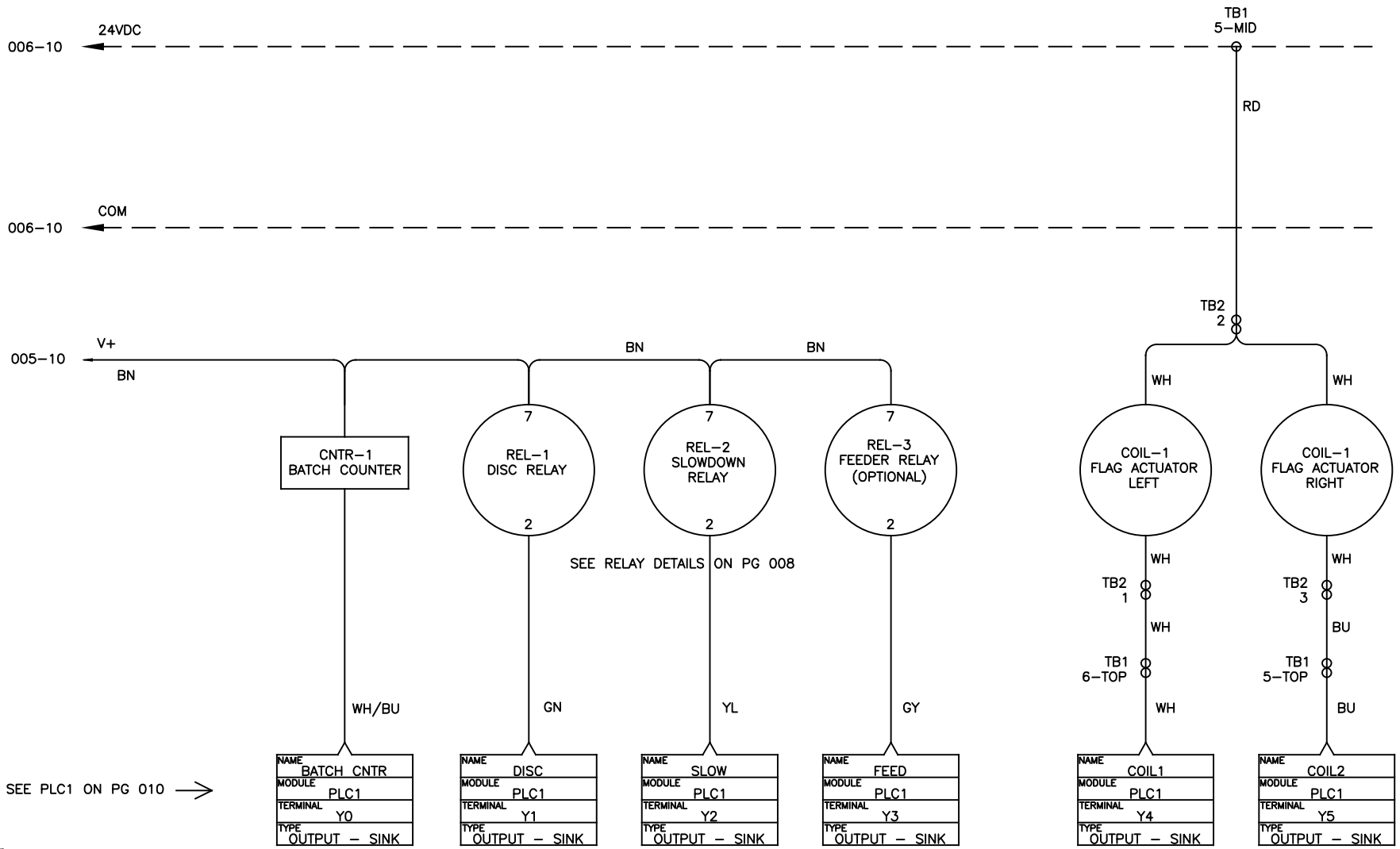

NUMBER  
SC1011  
  
 PAGE  
007

-	-	-	--/--/--
NOTE	REV	DESCRIPTION	DATE

DEITZ COMPANY, INC  
 ROUTE 34, WALL, N.J.  
 TECHNICAL DRAWING - PRODUCT INFO

SECTION	OUTPUTS: Y1 - Y5	BY	SJD2	DATE:	2007-11-09
TITLE	MODEL TC4 PILL COUNTER WIRING SCHEMATIC SERIAL NO. 001 AND UP		SHEET	007	
		NUMBER	SC1011		REVISION
					A

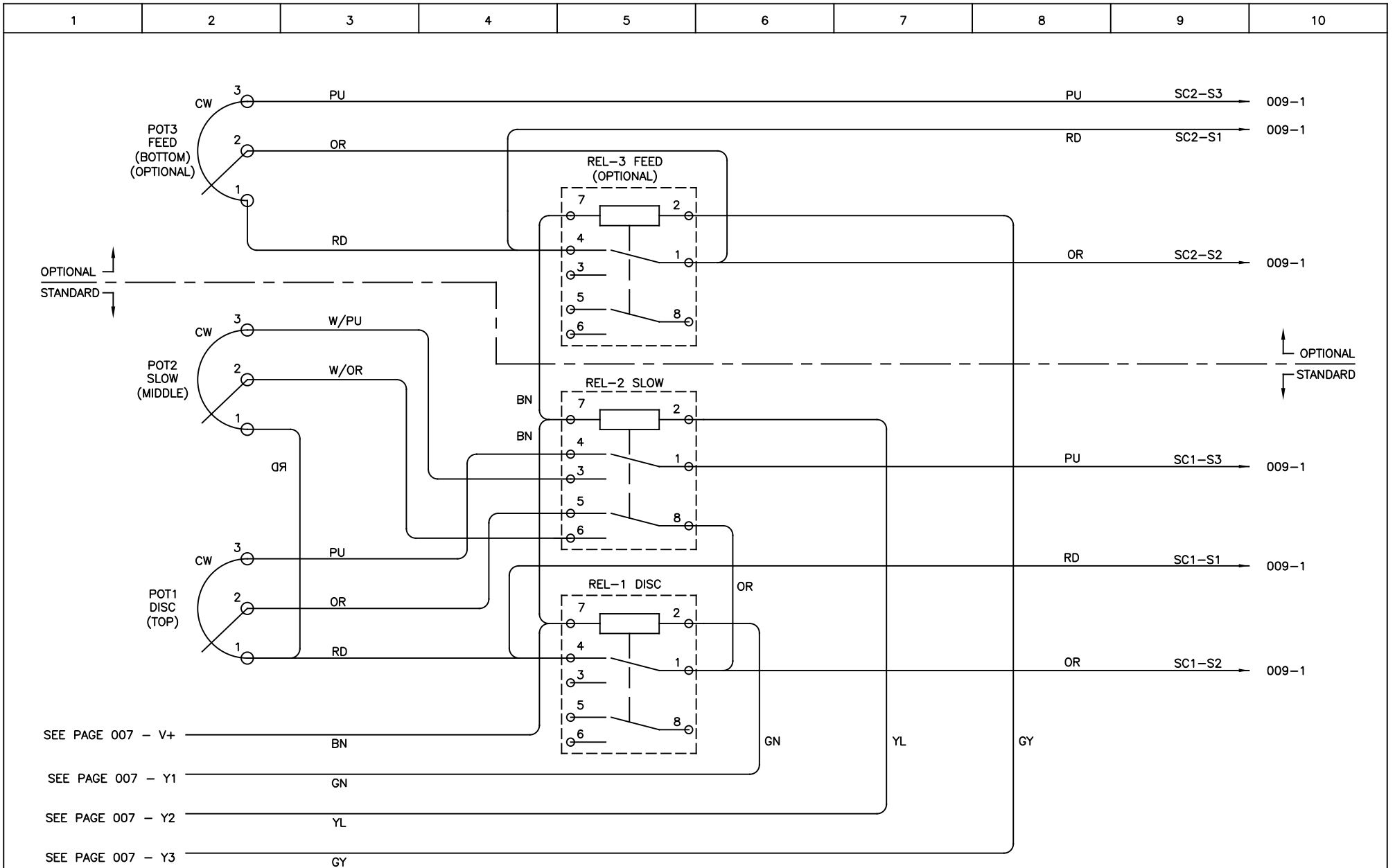

NUMBER  
 SC1011  
 PAGE  
 008

NOTE	REV	DESCRIPTION	DATE
-	-	-	---/---/---

DEITZ COMPANY, INC  
 ROUTE 34, WALL, N.J.  
 TECHNICAL DRAWING - PRODUCT INFO

SECTION	RELAYS AND POTS DETAILS	BY	SJD2	DATE:	2007-11-09
TITLE	MODEL TC4 PILL COUNTER WIRING SCHEMATIC SERIAL NO. 001 AND UP	SHEET	008		
		NUMBER	SC1011	REVISION	A

**SC1 SPEED CONTROL  
(MOTOR)**

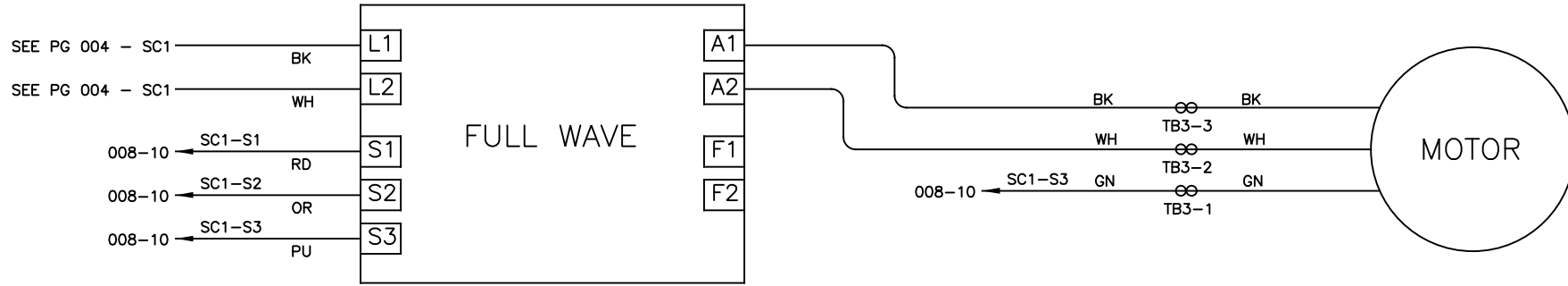

ALL UNITS ↑  
OPTIONAL ADD-ON ↓

ALL UNITS ↑  
OPTIONAL ADD-ON ↓

**SC2 SPEED CONTROL  
(FEEDER)**

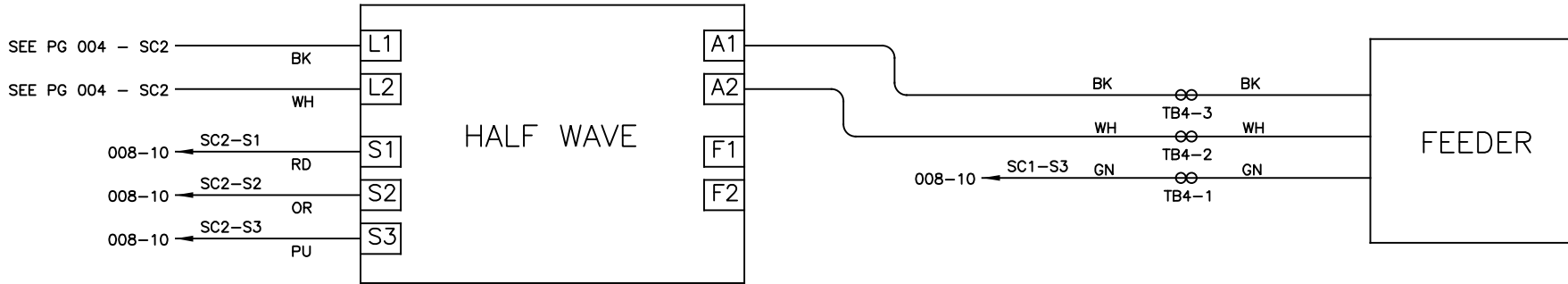

NUMBER  
SC1011  
  
 PAGE  
009

-	-	-	--/--/--
NOTE	REV	DESCRIPTION	DATE

<b>DEITZ COMPANY, INC</b> ROUTE 34, WALL, N.J. TECHNICAL DRAWING - PRODUCT INFO		SECTION SPEED CONTROLS DETAILS TITLE MODEL TC4 PILL COUNTER WIRING SCHEMATIC SERIAL NO. 001 AND UP	BY SJD2 DATE: 2007-11-09 SHEET 009 NUMBER SC1011 REVISION A
---	--	---	---



### PLC1 CONTROLLER

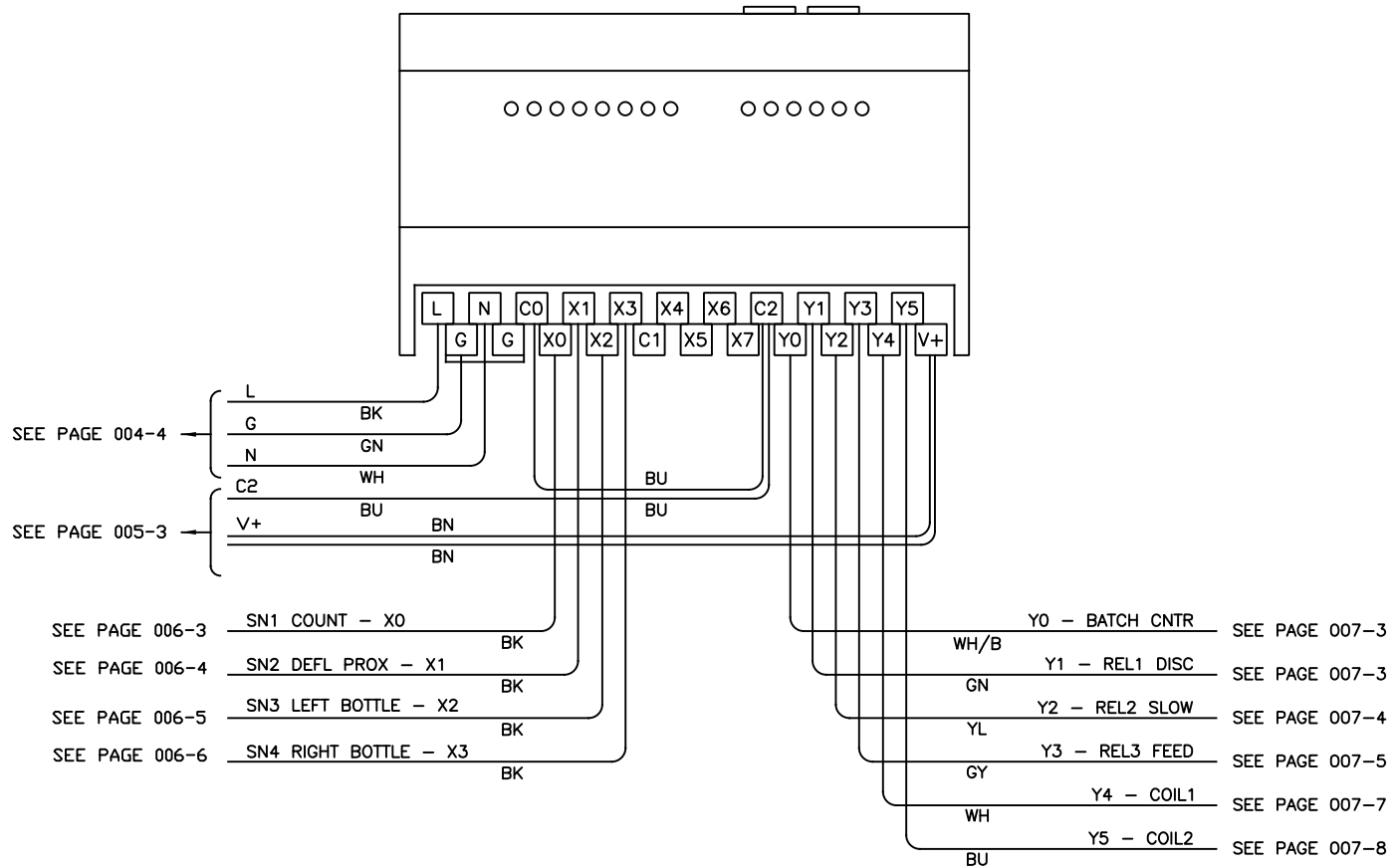

NUMBER  
 SC1011  
 PAGE  
 010

-	-	-	--/--/--
NOTE	REV	DESCRIPTION	DATE

DEITZ COMPANY, INC ROUTE 34, WALL, N.J.		SECTION    CONTROLLER (PLC)	BY    SJD2    DATE:    2007-11-09
TECHNICAL DRAWING - PRODUCT INFO		TITLE    MODEL TC4 PILL COUNTER WIRING SCHEMATIC SERIAL NO. 001 AND UP	SHEET    010 NUMBER    SC1007 REVISION    A